



STOLL

Operating instructions

Front loader **implements**

for the ProfiLine and Solid model series



Pallet fork HD/HS/Global

Bale tubes

Large bale fork

Large bale fork HS

Locking grate HS

Bale transport device H/rear

Bale spike H/Global/Skid

Manure fork

Log fork H

Bigbag lifter

Bag-Lift H

Load hook

Tenias adapter

MX implement adapter

Status: 12/2022

Company details**Wilhelm STOLL Maschinenfabrik GmbH**

PO box 1181, 38266 Lengede

Bahnhofstr. 21, 38268 Lengede

Phone: +49 (0) 53 44/20 -222

Fax: +49 (0) 53 44/20 -182

E-mail: info@stoll-germany.com

Web: www.stoll-germany.com

Spare Parts Order

Phone: +49 (0) 53 44/20 -144 and -266

Administration

Phone: +49 (0) 53 44/20 -145 and -146

Fax: +49 (0) 53 44/20 -183

E-mail: parts@stoll-germany.com

Copyright

© Wilhelm STOLL Maschinenfabrik GmbH

Reproduction of these instructions, both completely and in excerpts, is only allowed with approval from Wilhelm STOLL Maschinenfabrik GmbH. Any infringement shall entail full compensation of damages and can be punishable by law.

The original instructions were written in the German language.

Instructions in other languages were translated from German.

Contents

1	About these operating instructions	6
1.1	Documentation overview	6
1.2	Use and purpose of the operating instructions	7
1.3	Rating plate	7
1.4	Validity of the operating instructions	7
1.5	Storage of the documents	8
1.6	Other applicable documents	8
1.7	Design tools	8
1.8	Nomenclature of the footer	9
2	Safety	10
2.1	Explanation of safety and warning notices	10
2.2	Representation and layout of warning notices	10
2.3	Danger grading of warning notices	10
2.4	EC Conformity	10
2.5	Proper use	11
2.6	Foreseeable misuse	13
2.7	Operational limits	13
2.8	Basic safety information	13
2.9	Danger zones	19
2.10	Safety equipment	19
2.11	Safety stickers	20
2.11.1	Locking grate HS	20
2.11.2	Bigbag lifter	20
2.11.3	Load hook	21
2.11.4	MX implement adapter	21
2.12	Personnel requirements	22
2.13	Behaviour in case of emergency	23
2.13.1	Behaviour if the tractor tips or falls over	23
2.13.2	Behaviour in case of flashovers from electrical power lines	23
3	Implements	24
3.1	Pallet forks	24
3.1.1	Structure and description	24
3.1.2	Start-up	25
3.1.2.1	Initial operation	25
3.1.2.2	Check before each start-up	26
3.1.2.3	Mounting the implement	27
3.1.2.4	Installing the bale tines	27
3.1.3	Operation	28
3.1.4	Putting down the implement	28
3.2	Bale tubes	29
3.2.1	Structure and description	29
3.2.2	Start-up	29
3.2.2.1	Check before each start-up	29
3.2.2.2	Mounting the implement	29
3.3	Large bale fork	30
3.3.1	Structure and description	30
3.3.2	Start-up	31

3.3.2.1	Initial operation	31
3.3.2.2	Check before each start-up	31
3.3.2.3	Mounting the implement	32
3.3.3	Operation	33
3.3.4	Putting down the implement	33
3.4	Large bale fork HS	34
3.4.1	Structure and description	34
3.4.2	Start-up	35
3.4.2.1	Initial operation	35
3.4.2.2	Check before each start-up	37
3.4.2.3	Mounting the implement	37
3.4.3	Operation	38
3.4.4	Putting down the implement	38
3.5	Locking grate HS	39
3.5.1	Structure and description	39
3.5.2	Start-up	39
3.5.2.1	Check before each start-up	39
3.5.2.2	Mounting the implement	39
3.5.3	Operation	40
3.6	Bale transport devices	41
3.6.1	Structure and description	41
3.6.2	Start-up	42
3.6.2.1	Initial operation	42
3.6.2.2	Check before each start-up	43
3.6.2.3	Mounting the implement	43
3.6.3	Operation	45
3.6.4	Putting down the implement	45
3.6.4.1	Bale transport device H	45
3.6.4.2	Bale transport device rear	45
3.7	Bale spikes	46
3.7.1	Structure and description	46
3.7.2	Start-up	47
3.7.2.1	Initial operation	47
3.7.2.2	Check before each start-up	48
3.7.2.3	Mounting the implement	48
3.7.3	Operation	48
3.7.4	Putting down the implement	48
3.8	Manure forks	49
3.8.1	Structure and description	49
3.8.2	Start-up	50
3.8.2.1	Initial operation	50
3.8.2.2	Check before each start-up	52
3.8.2.3	Mounting the implement	52
3.8.3	Operation	52
3.8.4	Putting down the implement	52
3.9	Log fork H	53
3.9.1	Structure and description	53
3.9.2	Start-up	53
3.9.2.1	Initial operation	53
3.9.2.2	Check before each start-up	53
3.9.2.3	Mounting the implement	54

3.9.3	Operation	54
3.9.4	Putting down the implement	55
3.10	Bigbag lifter	56
3.10.1	Structure and description	56
3.10.2	Start-up	57
3.10.2.1	Initial operation	57
3.10.2.2	Check before each start-up	57
3.10.2.3	Mounting the implement	57
3.10.3	Operation	58
3.10.4	Putting down the implement	59
3.11	Bag-Lift H	60
3.11.1	Structure and description	60
3.11.2	Start-up	60
3.11.2.1	Initial operation	60
3.11.2.2	Check before each start-up	60
3.11.2.3	Mounting the implement	61
3.11.3	Operation	61
3.11.4	Putting down the implement	62
3.12	Load hook	62
3.12.1	Structure and description	62
3.12.2	Start-up	63
3.12.2.1	Initial operation	63
3.12.2.2	Check before each start-up	63
3.12.2.3	Mounting the implement	63
3.12.3	Operation	64
3.12.4	Putting down the implement	64
3.13	Tenias adapter	65
3.13.1	Structure and description	65
3.13.2	Start-up	65
3.13.2.1	Initial operation	65
3.13.2.2	Mounting the implement	66
3.14	MX implement adapter	67
3.14.1	Structure and description	67
3.14.2	Start-up	67
3.14.2.1	Initial operation	67
3.14.2.2	Mounting the implement	68
3.14.3	Putting down the implement	69
4	Troubleshooting	70
5	Servicing	72
5.1	Cleaning and care	73
5.1.1	Lubrication points	73
5.1.2	Lubrication schedule	74
5.2	Service	74
5.2.1	Service schedule	74
5.2.2	Service instructions for load hook	75
5.3	Repairs	75
6	Decommissioning	76
6.1	Temporary decommissioning	76
6.2	Recommissioning	77

6.3	Final decommissioning and disposal	77
7	Spare parts and customer service	77
7.1	Spare parts	77
7.2	Customer service	78
8	Technical specifications	78
8.1	Dimensions and weights	78
8.1.1	Pallet forks	78
8.1.1.1	Pallet fork HD	78
8.1.1.2	Pallet fork HS 1500	79
8.1.1.3	Pallet fork Global	79
8.1.2	Bale tubes	79
8.1.3	Large bale fork	79
8.1.4	Large bale fork HS	79
8.1.5	Locking grate HS	80
8.1.6	Bale transport devices	80
8.1.7	Bale spikes	80
8.1.7.1	Bale spike H	80
8.1.7.2	Bale spike Global	80
8.1.7.3	Bale spike Skid	81
8.1.8	Manure forks	81
8.1.9	Log fork H	81
8.1.10	Bigbag lifter	81
8.1.11	Bag-Lift H	82
8.1.12	Load hook	82
8.1.13	Tenias adapter	82
8.1.14	MX implement adapter	82
8.2	Noise emissions	82
8.3	Tightening torques for screws	83
9	Declaration of Conformity	84
	Index	86

1 About these operating instructions

1.1 Documentation overview

There are various instructions and technical documentation for the front loader, mounting kit and accessories. Most documents are available in multiple languages.

If a set of instructions is missing or required in a different language:

- Order the instructions through a dealer.
- Download instructions free of charge from the Internet at www.stoll-germany.com.

Installation instructions for the front loader mounting kit



The installation of the mounting kit as well as the hydraulic and electric equipment may only be performed by an authorised specialised workshop.

The installation instructions describe how to install the front loader mounting kit and the hydraulic and electrical equipment up to the initial start-up of the front loader. They are intended for the specialist workshop.

The installation instructions have been specially compiled for this tractor model. They do not contain any information that is already included in the operating instructions.

The installation instructions contain information on spare parts for the tractor-specific mounting parts and equipment.

Operating instructions of the front loader

These operating instructions describe the safe use of the front loader from the initial operation to its disposal. They are intended for the operator and the user of the front loader.

The operating instructions are compiled specifically for the front loader series, they can therefore only take tractor-specific equipment into account to a limited extent.

Spare parts list

The spare parts list of the front loader lists all the information required for ordering spare parts, the front loader series and their options. Special adaptations for the tractor are not taken into account.

In addition, spare parts lists are available for front loader implements.

Operating instructions for front loader implements

The operating instructions describe the implements available for the specified front loader series.

Other documents

In addition to the above instruction manuals, there may be installation and operating instructions as well as other Technical Information that deal with special additional equipment and extensions, which are not included in the other documentation.



When you pass on the front loader or the tractor with a front loader attached, please also hand over all the relevant documents. The next owner needs the information.

1.2 Use and purpose of the operating instructions

The present operating instructions contain important information on the safe operation and for faultless, proper, and economical operation of front loader implements from Wilhelm STOLL Maschinenfabrik GmbH. It is intended for the operator and user of the front loader implement and should help to prevent risks, damage and downtimes as well as ensure and increase the service life of the implements.

Before start-up of the implement, the operating instructions must be read and understood.

For better readability, Wilhelm STOLL Maschinenfabrik GmbH will be called "STOLL" in the following.

1.3 Rating plate

The implements are identified with a rating plate.

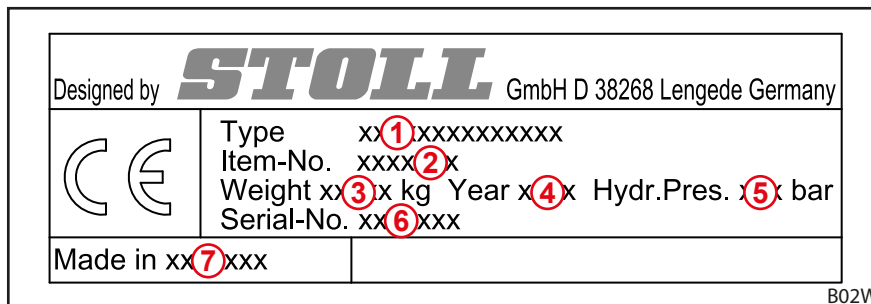

Fig. 1 Rating plate on the implement

Legend

- 1 Type of implement (e.g. round bale cutter)
- 2 Identification number
- 3 Weight
- 4 Year of manufacture
- 5 Permissible hydraulic pressure (not for all implements)
- 6 Serial number
- 7 Country of manufacture (e.g. ROK Republic of Korea)

1.4 Validity of the operating instructions

The operating instructions are valid only for STOLL Global and Profi implements listed under 2.5 *Proper use*, called "implement" in the following. The implement type can be found on the rating plate.

The operating instructions covers all of the components and functions of the model.

1.5 Storage of the documents

The operating instructions are a part of the machine. The entire documentation, consisting of these operating instructions as well as all other additional instructions supplied, must always be kept accessible, safe and dry on or in the vehicle. When lending or selling the front loader, the entire documentation must also be handed over.

1.6 Other applicable documents

In conjunction with these operating instructions, the following additional documents also apply:

- Operating instructions of the tractor
- Operating instructions of the front loader

When handling the implement and for all service work, please also observe:

- The recognised technical regulations for safe and professional work,
- The legal regulations for accident prevention,
- The legal regulations for health and environmental protection,
- The national regulations that apply in the country of the operator / user of the implement,
- The specifications that are relevant for the status of the technology,
- The road traffic regulations.

1.7 Design tools

The operating instructions contain the following different symbols and markings in the text:



Warning symbol that is used for warning notices and is graduated based on the danger (see 2 *Safety*)







Additional information and tips

- List points
- ➔ Requirement for a sequence of actions
- ✂ Required tools
- (1) Numbered action step
- ✓ Result of an action or sequence of actions
- Unnumbered action step

Moreover, stylised drawings are used. For better understanding, some of the figures are exemplary, simplified or with dismantled parts for better representation and explanation.

- Please observe the following:
 - Dismounting is not always absolutely required for the respective description.
 - No different equipment variations are shown in the figures, unless otherwise specified.
 - The associated descriptive text always applies to the figures.
 - The following representation rules and elements apply:

Representation	Meaning
	Elements represented in yellow highlight the components for the respective operating situation.
	Item numbers designate assemblies or components. In each figure, there is always an explanatory legend for the item numbers.
	Magnifying glasses serve to focus on individual parts and details.
	Arrows indicate a direction of movement or action to be performed.

1.8 Nomenclature of the footer

The footer consists of the following parameters:

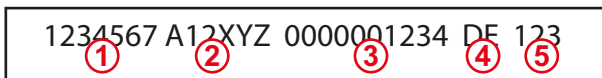

Fig. 2 Nomenclature of the footer

Legend

- 1 Document number (order number)
- 2 Type of instructions
- 3 Internal system number
- 4 Language identifier
- 5 Version

2 Safety

2.1 Explanation of safety and warning notices

The basic safety information comprises instructions that always apply for safe operation or to maintain the safe condition of the front loader and the front loader implements.

The action-related warning notices warn against residual dangers and are placed in front of dangerous action sequences.

2.2 Representation and layout of warning notices

Warning notices are action-related and are designed according to the following principle:

DANGER

Type and source of danger!

Explanation of the type and source of danger.

- ▶ Measures to prevent the danger.
-

2.3 Danger grading of warning notices

Warning notices are graded according to their level of danger and are represented as follows with the corresponding signal words and warning symbols:

DANGER

Immediate lethal danger or serious injuries.

WARNING

Possible lethal danger or serious injuries.

CAUTION

Possible slight injuries.

NOTICE

Damage to the implement or the surroundings.

2.4 EC Conformity

STOLL implements comply with Machinery Directive 2006/42/EC.

2.5 Proper use

The implements described are solely intended for use on agricultural or forestry tractors with a front loader and are intended for:

- mounting and use on tractors with STOLL front loaders from the ProfiLine and Solid model series as well as on tractors with front loaders approved by STOLL,
- use according to the usual purpose (see below),
- use and operation within the defined limits (see 8 *Technical specifications*),
- control from the driver's seat.

The information for its correct use and technical data in the operating instructions of the front loader apply in all other respects.

The implements may only be operated when they are in perfect condition. If faults impair safety, these must be promptly repaired by an authorised specialist workshop.

The implements may not be used in work processes that require the presence of people close to the load when the front loader is in the raised position! This kind of work is permitted only if the front loader is equipped with an anti-lowering guard (see front loader operating instructions).

The front loader and its implements must not be operated simultaneously with other hydraulic equipment on the tractor.

Proper use also includes reading and observing the operating instructions, the associated additional instructions, the other applicable documents as well as the safety information. To ensure operational safety, prescribed maintenance work as well as intervals and conditions for care and service must also be observed. Any use other or beyond those described in the manual is considered as improper use.

Purpose of the pallet forks

Pallet forks are intended for picking up, transporting, and putting down pallets and the loads secured on them for transport.

The pallet forks are designed to be mounted on the Euro change frame.

Purpose of the bale tubes

Bale tubes are an accessory for the pallet forks and may be used only on pallet tines with the ID numbers 3570710 and 3570720.

By installing bale tubes on the pallet fork, its intended use changes to such an extent that the transport of pallets is no longer possible.

With installed bale tubes, the pallet forks are intended for picking up and transporting round and wrapped bales (see bale transport device H). Only 1 bale can be picked up at a time.

Purpose of the large bale fork

The large bale fork is intended for loading and transporting high-pressure bales of hay, straw or similar materials.

The load must be picked up by both tines simultaneously. When loading and transporting stacked bales, the topmost bale may never protrude beyond the extended protection tubes. The stacked bales must be securely held by the protection tubes, so they must not be too narrow.

The large bale fork is intended for mounting on a Euro change frame.

Purpose of the large bale fork HS

The large bale fork HS is intended for loading and transporting high-pressure bales of hay, straw or similar materials.

The load must be picked up by both tines simultaneously. Only 1 bale can be picked up at a time.

The large bale fork HS is intended for mounting on a Euro change frame.

Purpose of the locking grate HS

The locking grate HS is an accessory for pallet forks HD and large bale forks HS and may be used only in conjunction with one of these implements.

The locking grate HS is intended for securing the load to the rear.

Purpose of the bale transport devices

The bale transport device H and the bale transport device rear are intended for picking up and transporting round and wrapped bales. Only 1 bale can be picked up at a time.

The bale transport device H is intended for mounting on a Euro change frame.

The bale transport device rear is mounted on the three-point hitch or the triangle device at the rear of the tractor. The bale transport device rear is intended for Category 2 mounting.

Purpose of the bale spikes

Bale spikes are intended for picking up and transporting round and square bales.

The load must be picked up by both tines simultaneously. Only 1 bale can be picked up at a time.

Bale spikes H and Global are intended for mounting on a Euro change frame.

The bale spike Skid is intended for mounting on a skid-steer change frame.

Purpose of the manure forks

Manure forks are intended for loading manure.

Manure forks are intended for mounting on a Euro change frame.

Manure forks with the ID numbers 3611820, 3611830, 3611930 and 3660460 may be used only with the front loaders FZ 60, 60.1, 80.1 and 100.

Purpose of the log fork H

Log fork H is intended for picking up, loading and pushing together tree trunks and other goods found in the forestry sector.

The log fork H is intended for mounting on a Euro change frame.

Purpose of the Bigbag lifter

The Bigbag lifter is intended for lifting, moving and loading bulk bags or Bigbags with 1 or 2 loops. The Bigbag lifter is not suitable for bulk bags or Bigbags with more loops.

The Bigbag lifter is intended for mounting on a Euro change frame.

Purpose of the Bag-Lift H

The Bag-Lift H is intended for lifting, moving and loading bulk bags or Bigbags with 4 loops. The Bag-Lift H is not suitable for bulk bags or Bigbags with fewer or more loops.

The Bag-Lift H is intended for mounting on a Euro change frame.

Purpose of the load hook

The load hook is intended for lifting and transporting loads that are equipped with a suitable load pick-up or a suitable load pick-up or sling gear.

The load hook is intended for mounting on a Euro change frame.

Intended purpose of the Tenias adapter

The Tenias adapter is a front loader adapter that is used to connect Tenias front loader implements and Euro change frames. The Tenias adapter may only be used in work processes that do not require the presence of people close to the load. The Tenias adapter may only be used in combination with STOLL front loaders and Tenias implements that are mounted on tractors.

When used as intended, the service life of the Tenias adapter is technically not limited.

Purpose of the MX implement adapter

The MX implement adapter is a front loader adapter that is used to connect implements with MX mounting and Euro change frames. The MX implement adapter may only be used in work processes that do not require the presence of people close to the load. The MX implement adapter may only be used in combination with STOLL front loaders from the ProfiLine model series and MX implements that are mounted on tractors.

When used as intended, the service life of the MX implement adapter is technically not limited.

2.6 Foreseeable misuse

Avoid the following:

- Use of the implements on a wheel loader or farm loader
- Exceeding of the permissible axle load and the permissible total weight of the tractor
- Use outside of the conditions and prerequisites that are specified in the technical manuals and documents
- Transport of persons
- Transport of loads that do not correspond to the purpose of the implements
- Transport of loads in road traffic
- Transport of unsecured loads (e.g. stone pallets)

2.7 Operational limits

- The following operating conditions and requirements on the operational environment must be observed:
 - If applicable, temperature range for proper operation of the tractor (see operating instructions of the tractor)
 - Sufficient load capacity of the tires and the front axle of the tractor

2.8 Basic safety information

The basic safety information comprises all safety measures grouped by theme and is applicable at all times. In addition, the information is presented as warning notices at the corresponding positions in these operating instructions.



The implements are intended for use with STOLL front loaders from the ProfilLine or Solid model series. Observe the safety instructions in the front loader operating instructions.

Basic dangers



Mortal danger exists when persons are lifted or carried with the front loader. The front loader is not equipped with the necessary safety equipment to be used as a work cage.

- It is forbidden to lift or transport people with the front loader.

Mechanical dangers



There is a risk of crushing and impact of the upper and lower limbs due to projecting or protruding frame parts and moving components of the machine.

- Personnel must be instructed in the proper use of the machine and in the location and types of danger.
- Instruct persons to exit the danger and movement areas of the machine.
- Wear suitable protective gear, if necessary, when performing service tasks.



There is a lethal risk of crushing and injury due to accidental movements of the tractor, the front loader, and the implements.

- Instruct persons to exit the danger and action area of the machine.
- Do not allow other people to assist in any way (e.g. holding of pasture fence posts if they are to be pressed into the ground with the front loader) and instruct people to exit the working area of the machine.
- Assistance from a second person for loading activities should only be allowed when the front loader is lowered, provided that an anti-lowering guard is not installed.
- For loading work as well as when mounting and dismounting the front loader, ensure that the tractor is standing on level and solid ground.
- Only operate the front loader from the driver's seat of the tractor. Operating elements outside of the tractor must not affect the front loader! In particular, the operating elements of the front linkage must not affect the front loader!
- The front loader must only be operated by one person.

There is a lethal risk of injury due to exceeding of the maximum permissible load or with improper use of the front loader resulting in breaking of the front loader or its components.

- Observe the load limits specified in the technical data.
- When transporting loads or levelling, do not drive faster than 10 km/h.
- When clearing, do not drive faster than 6 km/h.
- Work only with mounted and locked implement.
- Observe the load capacity of the tyres and the front axle of the tractor.

Electrical dangers



There is lethal danger due to power surges when touching live machine parts, e.g. due to short circuits in the on-board network of the tractor.

- Installation and service tasks on the electrical system should only be performed by an electrician.
- Observe the operating instructions of the tractor.



There is lethal danger due to collision of the raised front loader with high-voltage lines.

- Do not raise the front loader higher than 4 m when driving on roads.
- Keep a safe distance away from electrical lines.
- If you do not know the rated voltage, stay at least 4 m away from electrical lines.

Danger due to emissions



With long-lasting normal operation of the machine, hearing damage can be caused by the noise level of the tractor and the hydraulic system.

- Always wear personal hearing protection.
- Observe special regulations for road operation and for operating machines in open spaces.

Dangers during packaging and transport



There is a risk of injury due to crushing, impacts or pinching if the implement tips over or falls from the lifting gear.

- During all preparatory work and during transport, always ensure a secure stand of the machine.
- Assisting persons must be instructed to exit the immediate danger area under the implement.

There is a risk of accidents during transport of the implement if it is not correctly loaded and secured.

- The implement must be correctly secured and transported.

Dangers during installation for start-up



There is a risk of injury when lifting and handling heavy machine parts as well as bulky components of the implement.

- Heavy and bulky machine parts may only be lifted with the assistance of a second person.
- Avoid back injuries by lifting correctly.

Dangers when picking up and putting down implements



There is a risk of serious injury and lethal danger due to implements falling down or uncontrolled lowering of the front loader when unsuitable implements are used or if the used implements are overloaded.

- Check that the implements are suitable before use.
- Check that the implement is locked correctly by repeatedly putting the implement down on the ground.
- Perform a visual check on the locking device.
- Only perform the hydraulic locking of the implement up to a height of 1.5 m.
- Check the proper functioning of the implements one time without load before beginning work.

Dangers during excavation work



There is lethal danger and a risk of explosion during excavation work due to collision with cables buried in the ground.

- Before performing excavation work, ensure that there are no electric cables in the ground.
- Before performing excavation work, ensure that there are no gas lines in the ground.

Dangers during loading work



There is a risk of serious injury and mortal danger when loading and transporting loads, if the front loader is operated from one side, the load is raised too far over the driver's seat or if unsuitable implements are used.

- If not equipped, check for retrofitting a cab and/or a FOPS (falling objects protection structure) / ROPS (roll-over protection structure) within the framework of work safety regulations.
- If there is no cab or safety equipment, never lift loads over the driver's seat.
- Only use suitable implements, which prevent e.g. rolling back and falling on the driver's seat.

Dangers when operating the front loader



There is a risk of serious injury or lethal danger due to tipping of the tractor when working on slopes, when going around bends, when the load on the rear axle is too low, and when driving into the bulk to be lifted at a skewed angle.

The risk increases when the front loaders are raised up high because of the higher centre of gravity.

- Drive carefully when working on slopes. Never travel with a raised load across a slope.
- Ensure that the ground is level enough.
- When driving in curves, reduce the speed and lower the load.
- Never start driving abruptly with the front loader raised high and fully loaded.
- Observe and comply with the maximum load of the tractor.
- Always use sufficient counterweights at the rear of the tractor.
- In case of instability or tipping, lower the front loader and remain in the driver's cab.
- Drive towards the load in a straight line and do not steer while driving into the load.
- Use the safety belts.
- Connect the brake pedals.
- Switch off the front axle suspension.
- On tractors with adjustable track width: set the maximum possible track width.

When driving on roads, there is a risk of serious injury and lethal danger for the operator as well as for other road users if the tractor and the front loader are not correctly prepared and operated for road traffic.

- Only drive on roads without a load.
- Before driving on roads, switch off the hydraulic system and lock it.
- Raise the front loader.

Dangers due to falling loads

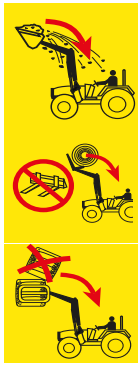

There is mortal danger due to raised loads falling down on the driver's seat. There is a particularly high risk when lifting pallets or bales above the driver's cab and when working on slopes. Even the standard protection systems (roll-over protection structure ROPS, falling objects protective structures FOPS) do not provide fully adequate protection.

- When working on slopes, reduce the implement filling and lower the load.
- Check the inclination of the implement. Do not scoop too far with the implement.
- Use implements that are designed such that they prevent loads from falling onto the driver's seat.
- Only use the appropriate implements when loading piece goods (e.g. bale grabber for bales or pallet fork for pallets).
- Lift pallets or bales one at a time. Never stack several loads on top of each other, since the top load could fall down on the driver's seat.
- Compensate for the increased angle on front loaders without parallel motion when lifting by "dumping" with the implement.
- Do not operate the front loader without parallel motion while driving in reverse.
- On tractors without a cab or 4-post roll-over protection structure, do not lift large load items, in particular bales, any higher than the pivot point of the lifting arm.
- Watch the load as you are lifting. Do not lift the load when reversing.

Dangers during maintenance



Improperly performed maintenance work (care and cleaning, service, repairs) impair the safety of the implements.

- Check the implements regularly for defects.
- Care and cleaning work must be carried out correctly.
- Only have repair work performed by authorised qualified personnel.

2.9 Danger zones

On and around the front loader, there are the following areas with increased risk to safety of the operator or safety of other persons:

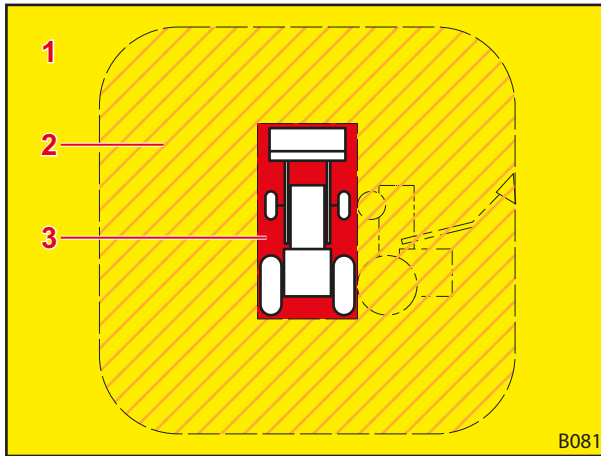

Fig. 3 Top view (from above)

Legend

- 1 Work area (yellow)
- 2 Outer danger zones (hatched in orange)
- 3 Inner danger zones (red)

Danger zone	Description	Danger
Work area	Overall possible movement area of the tractor incl. the front loader during loading work.	<ul style="list-style-type: none"> ● Standing in the working area represents a risk.
Outer danger zone	Overall field of action of the tractor and front loader as well as the area in which the tractor or front loader could tip over in case of accident: <ul style="list-style-type: none"> ● On the sides (left and right): height of the tractor with the front loader raised as far as it goes (incl. implement) ● Front and rear: half the height of the tractor with the front loader raised as far as it goes (incl. implement) 	<ul style="list-style-type: none"> ● When the tractor tips over or when loads fall down, people can be seriously injured.
Inner danger zone	Area on and around the tractor and front loader, especially between the wheels of the tractor, directly in front of and behind the tractor as well as on and under the front loader.	<ul style="list-style-type: none"> ● Persons can be pinched in between the wheels of the tractor. ● Persons can be overseen by the tractor driver and run over. ● Moving machine parts can move uncontrollably and thereby crush and injure people.

- Observe the danger zones and instruct unauthorised persons out of these areas.

2.10 Safety equipment

Depending on the type, the implements have the following protective and safety equipment:

Protective/safety equipment	Function
Safety stickers	Safety stickers warns against hazards at danger points (see 2.11 Safety stickers).

2.11 Safety stickers

Safety stickers warn of hazards at danger points and are an important part of the safety equipment of the front loader.

- Clean safety stickers if they are soiled.
- Replace damaged or illegible safety stickers (see 7.1 Spare parts).
- If necessary, equip new spare parts with the corresponding safety stickers.

2.11.1 Locking grate HS

Position and description of the safety stickers

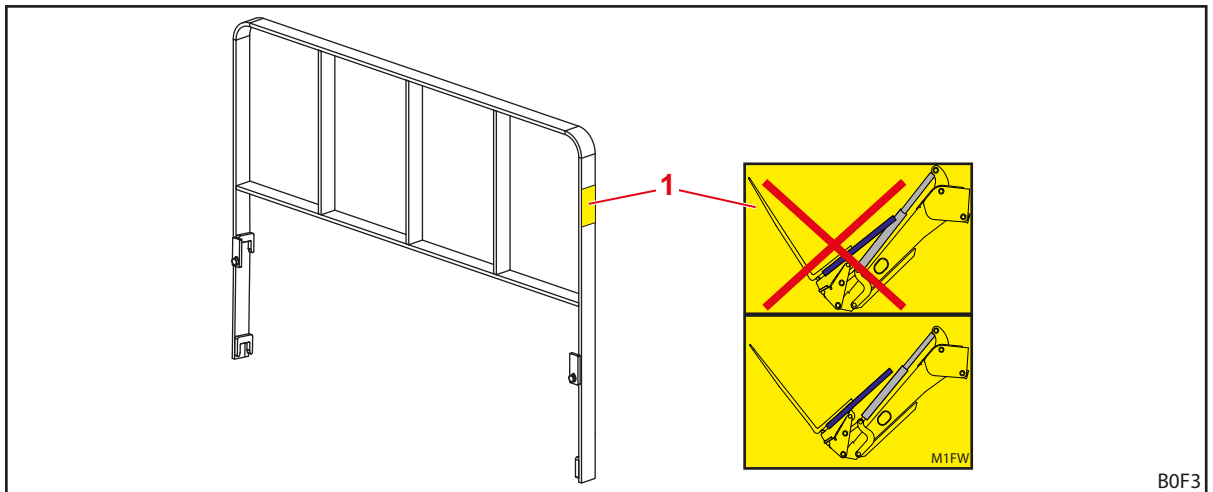

Fig. 4 Locking grate HS

Position	Description
1	Only scoop with the implement so far that the locking grate does not collide with the hydraulic cylinders.

2.11.2 Bigbag lifter

Position and description of the safety stickers

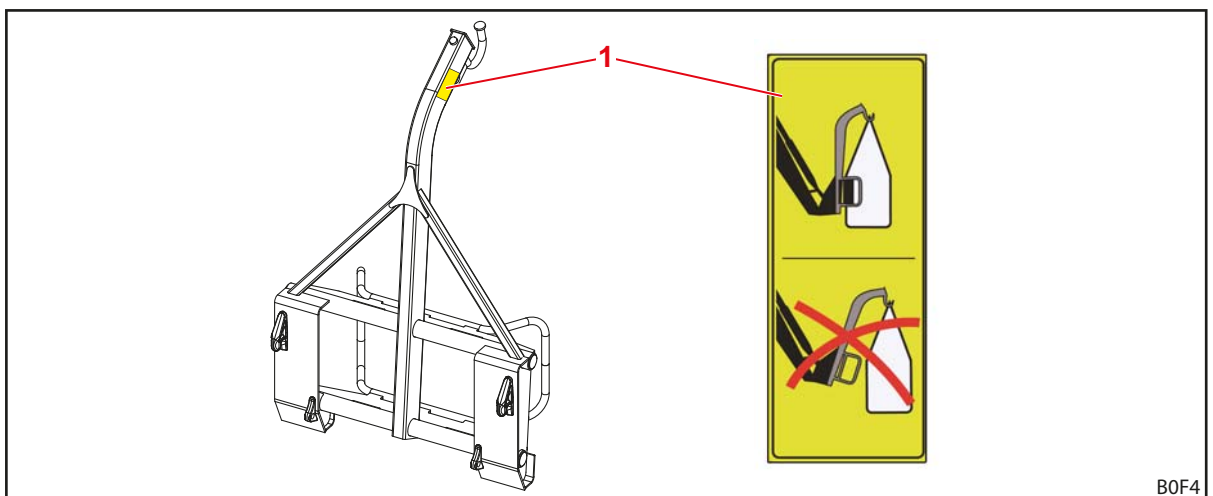

Fig. 5 Bigbag lifter

Position	Description
1	The Bigbag must rest completely against the swing limiter.

2.11.3 Load hook

Position and description of the safety stickers

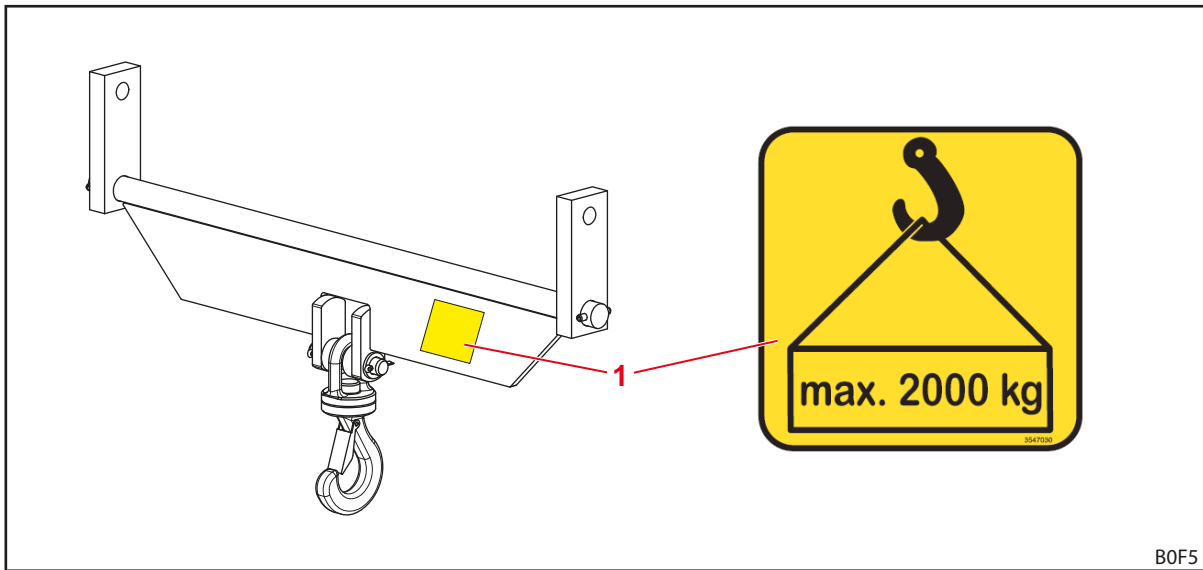

Fig. 6 Load hook

Position	Description
1	The implement can pick up a maximum load of 2000 kg.

2.11.4 MX implement adapter

Position and description of the safety stickers

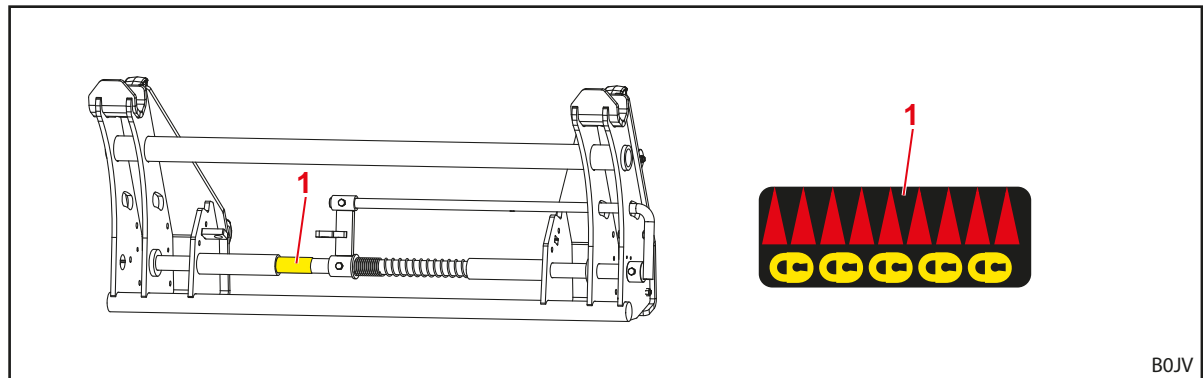

Fig. 7 MX implement adapter

Position	Description
1	Identification of the locked position of the mechanical implement locking mechanism.

2.12 Personnel requirements

In the operating instructions, a distinction is made between the following persons:

- Operators
- Qualified personnel
- Specialised tradesmen

All person groups must have read and understood the operating instructions. The table lists the other respective qualifications and responsibilities.

Personnel	Qualification/responsibility
Operators	<ul style="list-style-type: none"> • are responsible for the proper operation of the front loader • instruct qualified personnel on how to handle the front loader • ensure regular inspection and service of the front loader in a specialised workshop
Qualified personnel	<ul style="list-style-type: none"> • are responsible for the proper operation of the front loader • are physically able to control the front loader and the tractor • ensure regular service of the front loader • know the relevant road traffic regulations • are in possession of the prescribed driving license • are familiar with driving tractors safely
Specialised tradesmen	<ul style="list-style-type: none"> • perform maintenance work (service and repairs) • have a recognised training certificate or specialised knowledge that is required to observe the existing specifications, regulations, and directives



Work on electrical components of the machine may only be performed by an electrician according to the electro-technical regulations.

Welding work may only be performed in an authorised workshop.

2.13 Behaviour in case of emergency

- Initiate the following measures to avoid further damage in cases of emergency:
 - (1) Secure the accident site correctly.
 - (2) Provide first aid (if necessary).
 - (3) Call rescue workers, describe the situation briefly and concisely. Wait for feedback.
 - (4) Inform the employer or operator.

2.13.1 Behaviour if the tractor tips or falls over

- If the tractor tips or falls over with the front loader, observe the following instructions:
 - (1) Lower the load.
 - (2) Stay in the driver's cab until professional help arrives.

2.13.2 Behaviour in case of flashovers from electrical power lines

In the vicinity of electrical power lines, flashovers can happen quickly that cause high electrical voltage on the outside of the tractor. This results in large voltage differences on the ground around the machine.

In the case of a flashover:

- Do not exit the driver's cab.
- Do not touch any metal parts.
- There must be no connection to the earth.
- Warn any persons standing around against coming closer.
- Have the power switched off.
- Wait for professional rescue workers.

If it is still necessary to exit the driver's cab, e.g. due to the threat of fire:

- Jump away from the tractor and be sure not to touch it.
- Take small steps to move away from the tractor.

3 Implements

3.1 Pallet forks

3.1.1 Structure and description

The implement consists of the following components:

- 1 frame
- 2 pallet tines
- Tine sockets (depending on the model)

Depending on the model, the frame can be equipped with up to 4 tine sockets for installing bale tines. By installing the bale tines, the implement is turned into a bale spike (operating instructions see 3.7 *Bale spikes*).

The frame is equipped with 2 support hooks and 2 support lugs for the Euro change frame.

The pallet tines are variably adjustable and each is equipped with 1 locking lever to latch onto the frame.

The two hexagonal screws M10x25 at the end of the frame profile serve as tine stops and prevent the pallet tines from slipping off the frame.

As an option, the pallet fork can also be equipped a locking grate (see 3.5 *Locking grate HS*).

As an option, the pallet tines of the pallet fork HS can be equipped with bales tubes (see 3.2 *Bale tubes*).

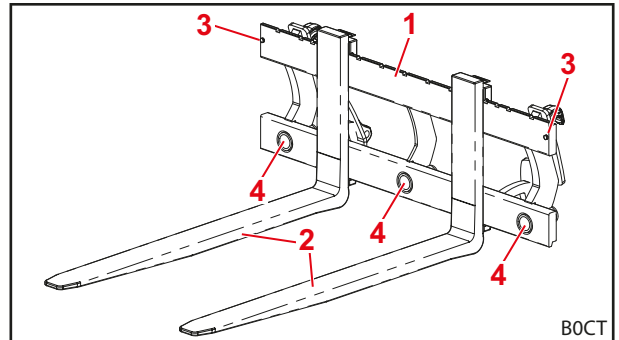

Fig. 8 Structure of the pallet fork HD with tine sockets – front view

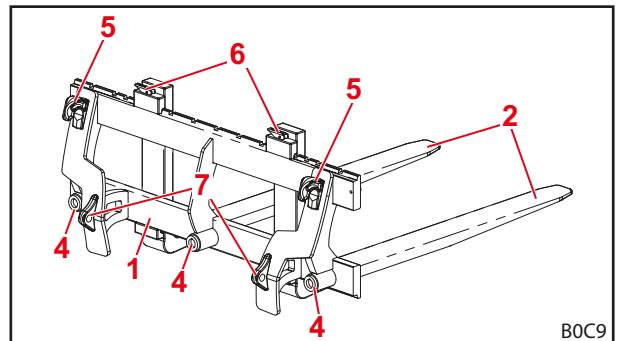

Fig. 9 Structure of the pallet fork HD with tine sockets – rear view

Legend

- 1 Frame
- 2 Pallet tine
- 3 Hexagonal screws M10x25
- 4 Tine sockets
- 5 Support hooks for change frame
- 6 Locking lever for the pallet tines
- 7 Support lugs for pins of the change frame

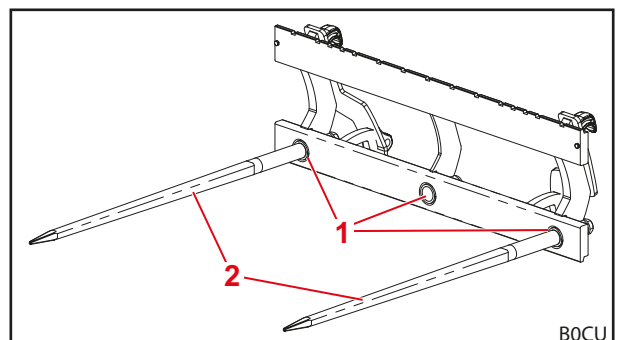

Fig. 10 Pallet fork HD with bale tines

Legend

- 1 Tine sockets
- 2 Bale tines

3.1.2 Start-up

3.1.2.1 Initial operation

The initial operation is performed at a specialist workshop. This also includes mounting of the implement as well as a functional check.

- Obtain instruction from the specialised workshop and ask questions if necessary.
- Read the operating instructions before initial use.
- Check all of the implement functions without a load.
- Check proper functioning of the implement under all operating states.

⚠ WARNING

Risk of injury due to implements falling down!

The implement may fall down if the implement locking mechanism is open or not locked correctly. This can cause serious injury to persons standing in the surrounding area.

- ▶ Only actuate the implement locking mechanism when the implement is set down on the ground or on a secure rack.
- ▶ Always check that the implement is correctly locked.

Before initial start-up, the pallet tines must be installed on the frame.

Installing the pallet tines on the frame:

- (1) Lower the front loader just above the ground.
- (2) Switch off the tractor.
 - Stop the engine.
 - Apply the parking brake.
- (3) Lift the frame using a crane and hook onto the change frame of the front loader with the support hooks.
- (4) Close the implement locking mechanism (see front loader operating instructions).

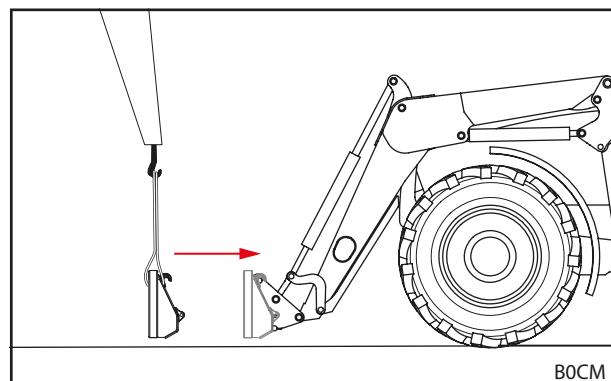

Fig. 11 Hooking the frame onto the change frame

- (5) Remove the hexagonal screw M10x25 at the end of the frame profile.

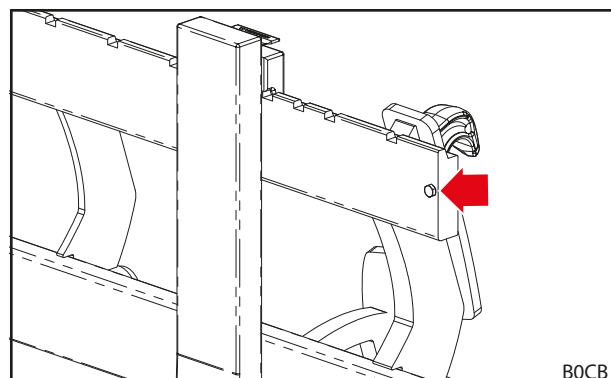

Fig. 12 Removing the hexagonal screw at the end of the profile

- (6) Slide the pallet tines onto the frame from the side.

i In doing so, the locking lever of the pallet tines must be in the vertical position.

- (7) Reinstall the hexagonal screw M10x25 at the end of the frame profile.
- (8) Lock the pallet tines in the desired position with the locking lever.
 - Slide the pallet tines to the desired position.
 - Move the locking lever of the pallet tines in the horizontal position to lock the pallet tines.
 - Check the locking mechanism.

i The locking mechanism is only correctly closed when the locking lever is horizontal and is resting on the guide pocket. Only in this case was the pin of the locking lever pushed into one of the notches on the frame profile and the pallet tine is secured against slipping to the side.

- (9) Install the second pallet tine in the same way.
- (10) Switch on the tractor.
- (11) Carefully move the implement to all of the end positions to ensure that it works without collisions.
 - ✓ The pallet tines are installed on the frame.

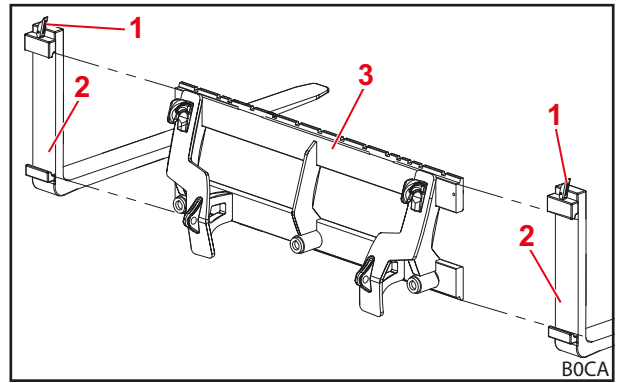

Fig. 13 Sliding the pallet tines onto the frame

Legend

- 1 Locking lever
- 2 Pallet tine
- 3 Beam

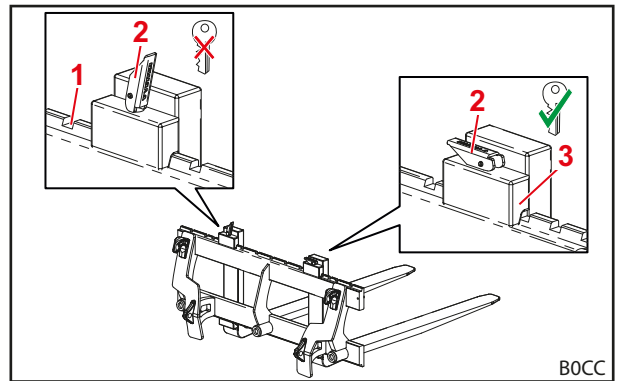

Fig. 14 Locking mechanism of the pallet tines (left – open, right – closed)

Legend

- 1 Notch
- 2 Locking lever
- 3 Guide pocket

3.1.2.2 Check before each start-up

- Before each start-up, check all of the points on the checklist.
- Fix any observed defects in a safe position and location.
- Use the implement only if proper and safe operation is ensured.

	Checks	See also	Completed
Before mounting the implement			
	Is the correct counterweight mounted on the rear?	see front loader operating instructions	
	Visual check performed on the implement for damage (e.g. cracks, corrosion)?		
After mounting the implement			
	Is the locking mechanism for the implement locked properly?	see front loader operating instructions	
	Is the locking mechanism for the tines correctly locked?	See initial operation	
	If accessories were installed: Are the accessories correctly installed/locked?	See chapter for the respective accessory	
	Ensured that the implement cannot collide with the front loader in any position?		

3.1.2.3 Mounting the implement

The implement is intended for mounting on a Euro change frame.

- In doing so, observe the description and warnings for mounting implements and operation of the implement locking mechanism in the front loader operating instructions.

3.1.2.4 Installing the bale tines

For pallet forks with tine sockets, bale tines can also be installed instead of the pallet tines.

Installing the bale tines on the frame:

- ✂ Open-ended spanner 41 mm WAF
 - ✂ Torque wrench
- (1) Install the implement on the front loader (see 3.1.2.3 *Mounting the implement*).
 - (2) Lower the front loader just above the ground.
 - (3) Remove the pallet tines from the frame.
 - Remove the hexagonal screw M10x25 at the end of the frame profile.
 - Move the locking lever for the pallet tines to the vertical position and remove the pallet tines from the frame.
 - Reinstall the hexagonal screw M10x25 at the end of the frame profile.
- ✓ The pallet tines have been removed from the frame.

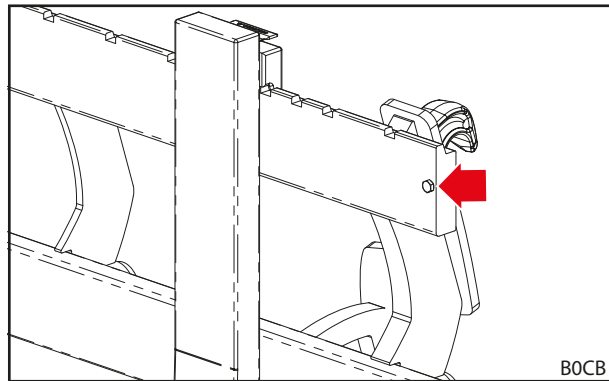

Fig. 15 Removing the hexagonal screw at the end of the profile

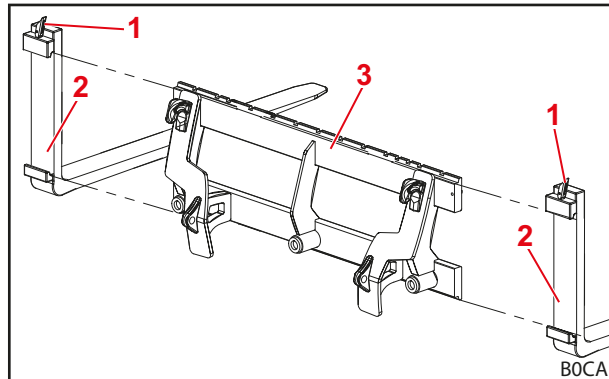

Fig. 16 Removing the pallet tines from the frame

Legend

- 1 Locking lever
- 2 Pallet tine
- 3 Beam

- (4) Remove the hexagonal nut from the bale tine.
- (5) Insert the bale tines through the tine socket from the front.
- (6) Install the hexagonal nut back on the bale tine from the rear.

i Tightening torque: 1840 Nm

- (7) Proceed in the same way for the remaining bale tines.
 - (8) Carefully move the implement to all of the end positions to ensure that it works without collisions.
- ✓ The bale tines are installed on the frame.

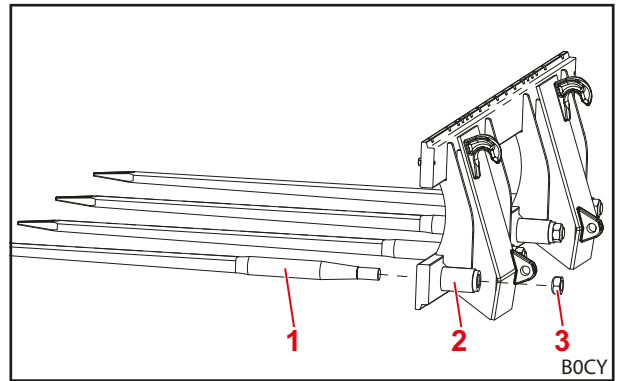

Fig. 17 Installing the bale tines on the frame

Legend

- 1 Bale tines
- 2 Head
- 3 Hexagonal nut
- 4 Beam

3.1.3 Operation

Picking up and unloading loads:

➔ Before beginning operation, check that the implement functions properly and safely without a load.

- (1) If necessary, adjust the spacing of the pallet tines for the width of the pallet to be transported (see 3.1.2.1 Initial operation).

i If the pallet tines do not move easily, lubricate the frame profile.

- (2) Lower the front loader until it is just above the ground and position the implement horizontally.
- (3) Carefully drive into the pallet with the pallet tines.
- (4) Lift the load.

i Lift the load only as high as necessary for transport.

- (5) Drive the load to the target site.
 - (6) Put down the load and carefully drive out of the pallet.
- ✓ The load has been picked up and unloaded.

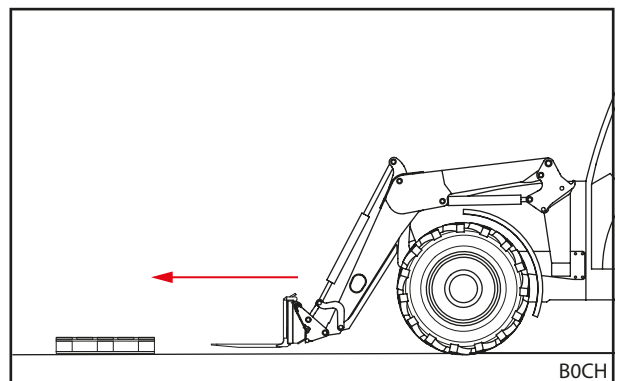

Fig. 18 Driving into the pallet

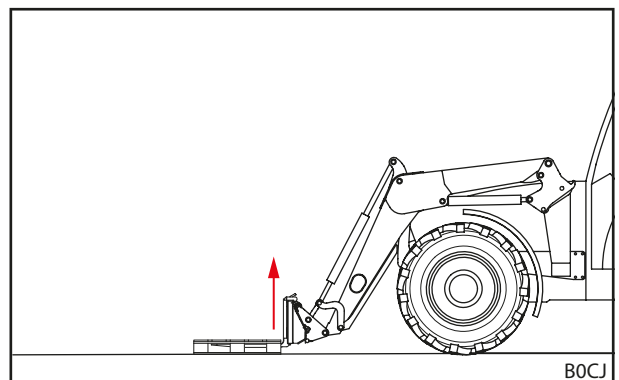

Fig. 19 Lifting the load

3.1.4 Putting down the implement

➤ see 6.1 Temporary decommissioning

3.2 Bale tubes

3.2.1 Structure and description

The implement consists of the following components:

- 2 bale tubes

The bale tubes enable rounding of the sharp edges of the pallet tines.

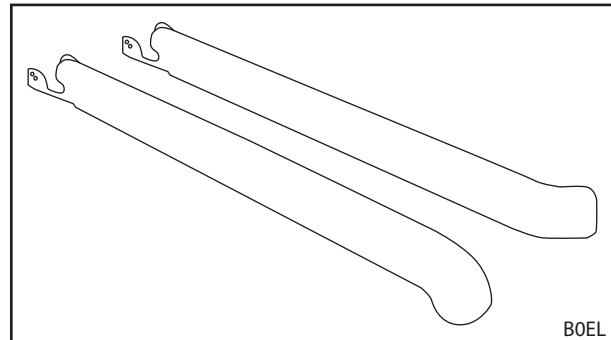

Fig. 20 Structure of the bale tubes

3.2.2 Start-up

3.2.2.1 Check before each start-up

- See chapter "Check before each start-up" for the implement on which this accessory is installed.

3.2.2.2 Mounting the implement

Installing the bale tubes on the pallet tines:

- (1) Lower the pallet fork until it is just above the ground.
- (2) Switch off the tractor.
 - Stop the engine.
 - Apply the parking brake.
- (3) Slide the bale tube onto the pallet tine.

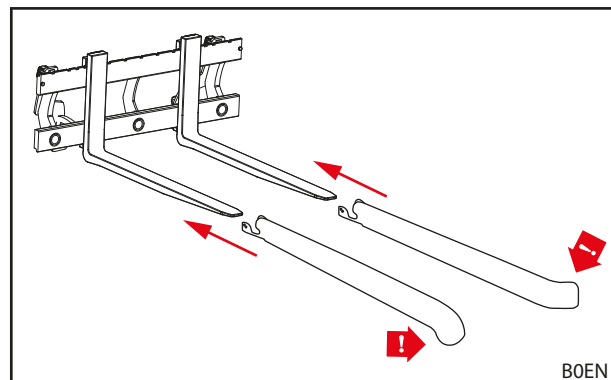

Fig. 21 Sliding the bale tubes onto the pallet tines

- (4) Install the bale tube on the pallet tine with 1 hexagonal screw M12x160 and 1 lock nut.
 - (5) Install the second bale tube in the same way.
 - (6) Switch on the tractor.
 - (7) Carefully move the implement to all of the end positions to ensure that it works without collisions.
- ✓ The bale tubes are installed on the pallet tines.

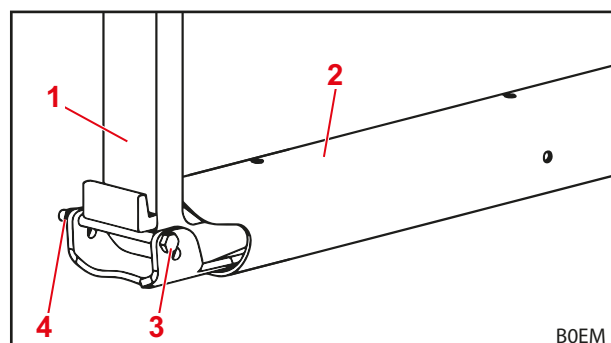

Fig. 22 Installing the bale tube on the pallet tine

Legend

- 1 Bale tube
- 2 Pallet tine
- 3 Hexagonal screw M12x160
- 4 Lock nut

3.3 Large bale fork

3.3.1 Structure and description

The implement consists of the following components:

- 1 frame
- 2 protection tubes with securing pins
- 2 tines (folding) with securing pins

The frame is equipped with 2 support hooks and 2 support lugs for the Euro change frame.

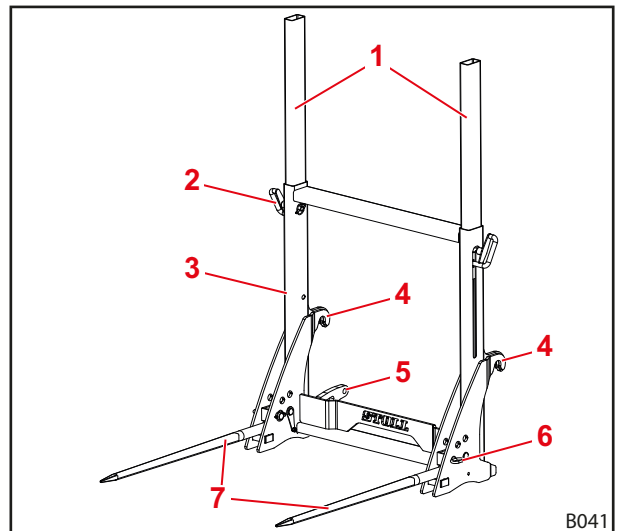

Fig. 23 Structure of the large bale fork

Legend

- 1 Protection tubes
- 2 Securing pin for protection tube
- 3 Frame
- 4 Support hooks for change frame
- 5 Support lugs for pins of the change frame
- 6 Securing pin for the tine
- 7 Tines

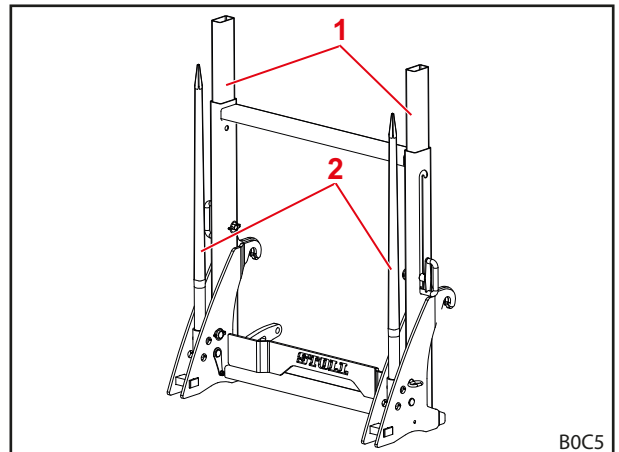

Fig. 24 Preparing the large bale fork for driving on roads

Legend

- 1 Protection tubes (pushed in and secured)
- 2 Tines (folded up and secured)

3.3.2 Start-up

3.3.2.1 Initial operation

The initial operation is performed at a specialist workshop. This also includes mounting of the implement as well as a functional check.

- Obtain instruction from the specialised workshop and ask questions if necessary.
- Read the operating instructions before initial use.
- Check all of the implement functions without a load.
- Check proper functioning of the implement under all operating states.

3.3.2.2 Check before each start-up

- Before each start-up, check all of the points on the checklist.
- Fix any observed defects in a safe position and location.
- Use the implement only if proper and safe operation is ensured.

	Checks	See also	Completed
<i>Before mounting the implement</i>			
	Is the correct counterweight mounted on the rear?	see front loader operating instructions	
	Visual check performed on the implement for damage (e.g. cracks, corrosion)?		
<i>After mounting the implement</i>			
	Is the locking mechanism for the implement locked properly?	see front loader operating instructions	
	Ensured that the implement cannot collide with the front loader in any position?		

3.3.2.3 Mounting the implement

The implement is intended for mounting on a Euro change frame.

- In doing so, observe the description and warnings for mounting implements and operation of the implement locking mechanism in the front loader operating instructions.

Preparing for driving on roads

- (1) Slide on the protection tubes on both sides.
 - Pull out the lynch pin.
 - Pull out the securing pin by the handle and unhook it.
 - Push down the protection tube with the handle of the securing pin.
 - Insert the securing pin and secure with the lynch pin.
 - (2) Swivel up the tines on both sides.
 - Pull out the lynch pin.
 - Pull out the securing pin by the handle.
 - Fold up the tines.
 - Insert the securing pin in the top hole and secure with the lynch pin.
- ✓ The implement is ready for driving on roads.

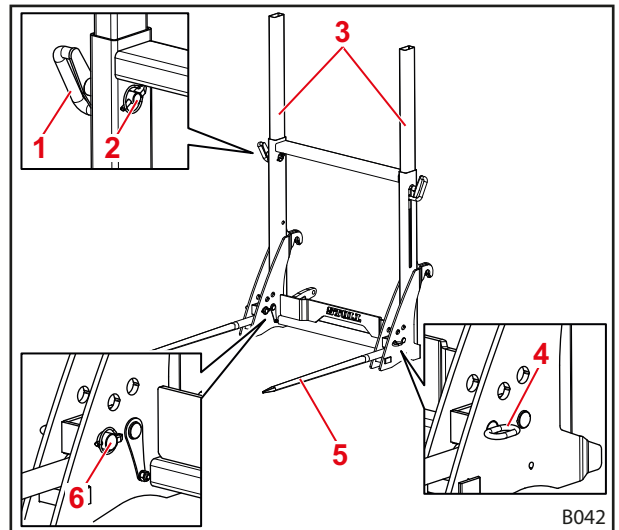

Fig. 25 Preparing for driving on roads

Legend

- 1 Securing pin for protection tube
- 2 Lynch pin for protection tube
- 3 Protection tubes
- 4 Securing pin for the tine
- 5 Tines
- 6 Lynch pin for tines

Preparing for working with bales

- (1) Pull out the protection tubes on both sides.
 - Pull out the lynch pin.
 - Pull out the securing pin by the handle.
 - Slide up the protection tube with the handle of the securing pin.
 - Hook on the securing pin, slide in and secure with the lynch pin.
 - (2) Swivel down the tines on both sides.
 - Pull out the lynch pin.
 - Pull out the securing pin by the handle.
 - Fold down the tines.
 - Insert the securing pin in the bottom hole and secure with the lynch pin.
- ✓ The implement is prepared for working with bales.

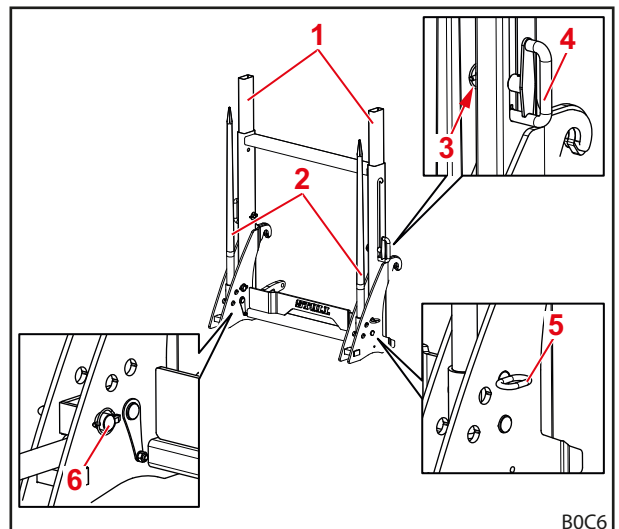

Fig. 26 Preparing for working with bales

Legend

- 1 Protection tubes
- 2 Tines
- 3 Lynch pin for protection tube
- 4 Securing pin for protection tube
- 5 Securing pin for the tine
- 6 Lynch pin for tines

3.3.3 Operation

⚠ WARNING

Risk of accident when driving on roads due to protruding tines or the protection tubes standing too high!

In case of accidents in road traffic, other road users can be severely injured by protruding tines. When the protection tubes are standing too high, there can be collisions with power lines, bridges, trees, etc.

- ▶ Fold up the tines.
- ▶ Slide on the protection tubes.
- ▶ When the front loader is raised, swivel the large bale fork as far to the rear as possible (*scooping* function of the front loader).

⚠ WARNING

Lethal danger due to bales falling down!

Stacked bales can easily fall to the rear from the raised bale fork and then fall, roll or slip over the front loader onto the driver. This can cause lethal injuries to the driver.

- ▶ Before working with stacked bales, pull out the protection tubes.
- ▶ Only stack bales that are considerably wider than the spacing of the protection tubes.
- ▶ Only lift bale stacks when the topmost bale does not protrude beyond the protection tubes.

Stacking bales:

➔ Before beginning operation, check that the implement functions properly and safely without a load.

- (1) Position the implement horizontally.
- (2) Lower the front loader until the implement is positioned about in the middle in front of the large bale or lowest bale of the bale stack.
- (3) Slowly drive the tractor forwards and drive into the large bale or bale stack with the tines until it touches the frame.

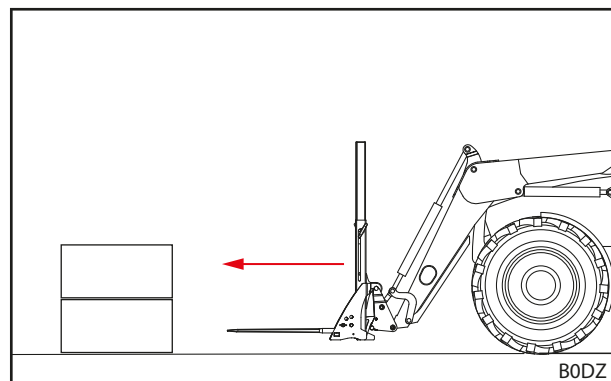

Fig. 27 Driving into the bale stack

- (4) Tilt the implement by at least 20° to the rear.
- (5) Raise the front loader if necessary.

i Lift the bales only slightly when driving. Only lift the bales for the stacking procedure.

- (6) After reaching the stacking position, slowly lower/put down the large bale or bale stack.

i In doing so, position the tines horizontally again.

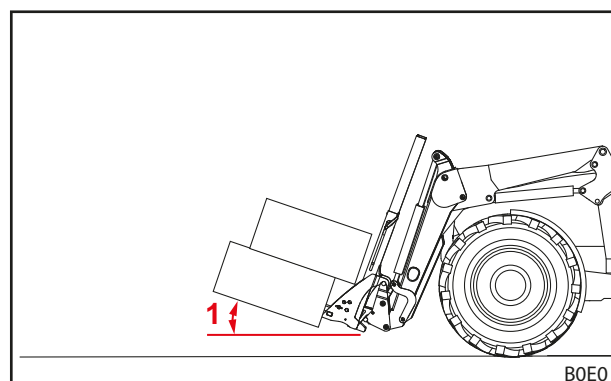

Fig. 28 Tilting the implement to the rear

Legend

- 1 Scooping angle of at least 20°

- (7) Slowly drive in reverse.

✓ The bales have been stacked.

3.3.4 Putting down the implement

- see 6.1 Temporary decommissioning

3.4 Large bale fork HS

3.4.1 Structure and description

The implement consists of the following components:

- 1 frame with support hooks for Euro change frame
- 2 bale tines with securing pins

The frame is equipped with 2 support hooks and 2 support lugs for the Euro change frame.

The bale tines are variably adjustable and each is equipped with 1 locking lever to latch onto the frame.

The two hexagonal screws M10x25 at the end of the frame profile serve as tine stops and prevent the bale tines from slipping off the frame.

As an option, the large bale fork HS can also be equipped a locking grate (see 3.5 *Locking grate HS*).

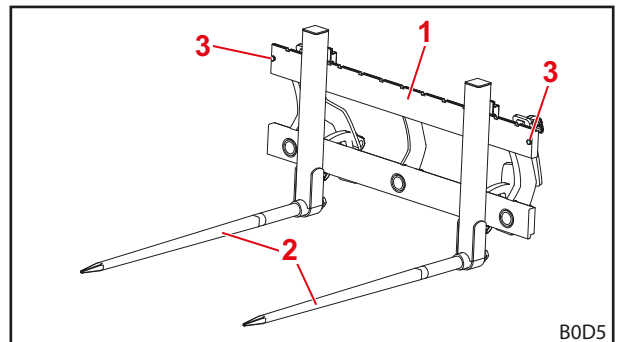

Fig. 29 Structure of the large bale fork HS – front view (example: with standard tines)

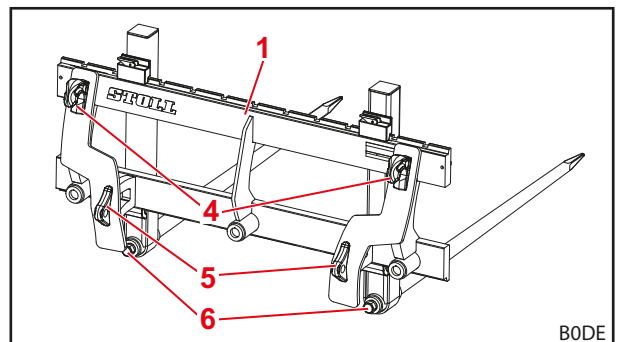

Fig. 30 Structure of the large bale fork HS – rear view (example: with standard tines)

Legend

- 1 Frame
- 2 Bale tines
- 3 Hexagonal screws M10x25
- 4 Mounts for the change frame
- 5 Support lugs for pins of the change frame
- 6 Securing pins for bale tines

Depending on the bale tine version, they can be folded up.

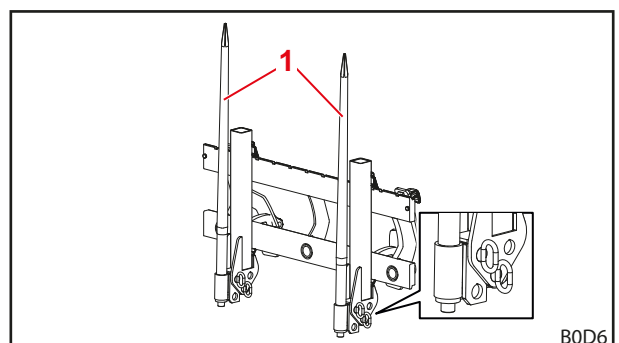

Fig. 31 Large bale fork HS with foldable tines prepared for driving on roads

Legend

- 1 Bale tines (folded up and secured)

3.4.2 Start-up

3.4.2.1 Initial operation

The initial operation is performed at a specialist workshop. This also includes mounting of the implement as well as a functional check.

- Obtain instruction from the specialised workshop and ask questions if necessary.
- Read the operating instructions before initial use.
- Check all of the implement functions without a load.
- Check proper functioning of the implement under all operating states.

⚠ WARNING

Risk of injury due to implements falling down!

The implement may fall down if the implement locking mechanism is open or not locked correctly. This can cause serious injury to persons standing in the surrounding area.

- ▶ Only actuate the implement locking mechanism when the implement is set down on the ground or on a secure rack.
- ▶ Always check that the implement is correctly locked.

Before initial start-up, the bale tines must be installed on the frame.

Installing the bale tines on the frame:

- (1) Lower the front loader just above the ground.
- (2) Switch off the tractor.
 - Stop the engine.
 - Apply the parking brake.
- (3) Lift the frame using a crane and hook onto the change frame of the front loader with the support hooks.
- (4) Close the implement locking mechanism (see front loader operating instructions).

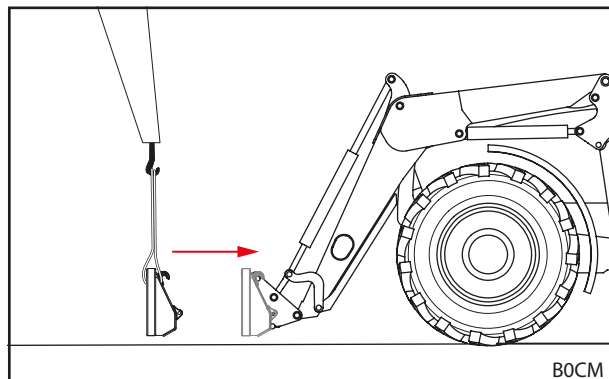

Fig. 32 Hooking the frame onto the change frame

- (5) Remove the hexagonal screw M10x25 at the end of the frame profile.

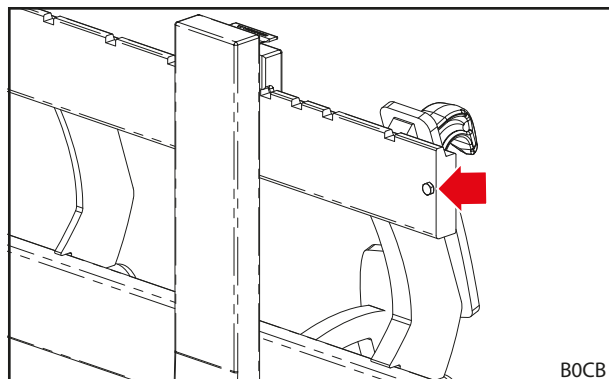

Fig. 33 Removing the hexagonal screw at the end of the profile

- (6) Slide the frame part for the left bale tine onto the frame from the side.

i In doing so, the locking lever of the frame part must be in the vertical position.

- (7) Reinstall the hexagonal screw M10x25 at the end of the frame profile.

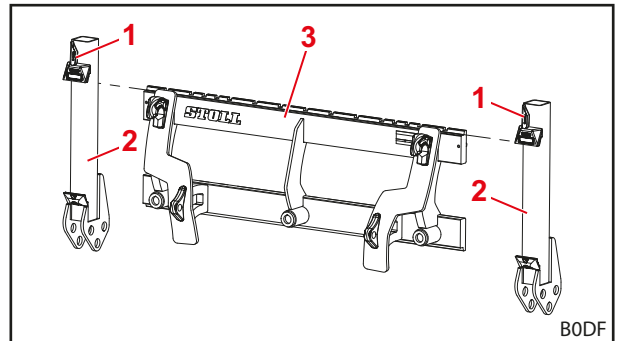

Fig. 34 Slide the frame parts on the frame (example: large bale fork HS with foldable tines)

Legend

- 1 Locking lever
- 2 Frame parts of the bale tines
- 3 Beam

- (8) Lock the frame part in the desired position with the locking lever.

- Slide the frame part to the desired position.
- Move the locking lever of the frame part in the horizontal position to lock the frame part.
- Check the locking mechanism.

i The locking mechanism is only correctly closed when the locking lever is horizontal and is resting on the guide pocket. Only in this case was the pin of the locking lever pushed into one of the notches on the frame profile and the bale tine is secured against slipping to the side.

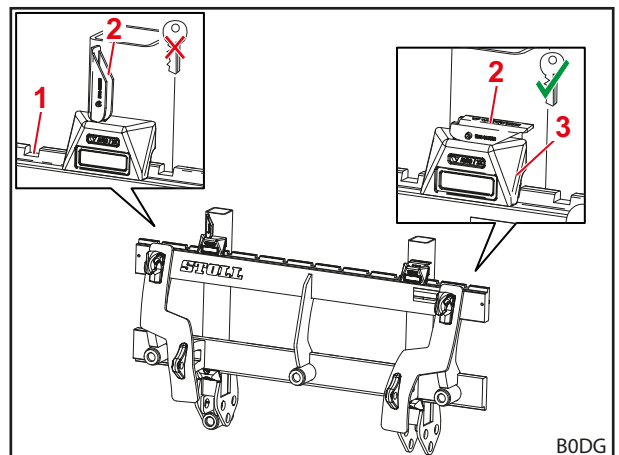

Fig. 35 Locking mechanism of the frame part (left – open, right – closed)

Legend

- 1 Notch
- 2 Locking lever
- 3 Guide pocket

- (9) Install the frame part for the right bale tine in the same way.

Large bale fork HS with standard tines:

- ✘ Open-ended spanner 41 mm WAF
- ✘ Torque wrench

(10) Install the bale tines on the frame part.

- Remove the castle nut from the left bale tine.
- Insert the left bale tine through the frame part and fasten on the other side with the castle nut.



Tightening torque: 1840 Nm

- Install the right bale tine in the same way.

Large bale fork HS with foldable tines:

(11) Install the bale tines on the frame part.

- Lock the left bale tine with 2 connectors and 2 linch pins in the two top holes of the frame part.
- Install the right bale tine in the same way.

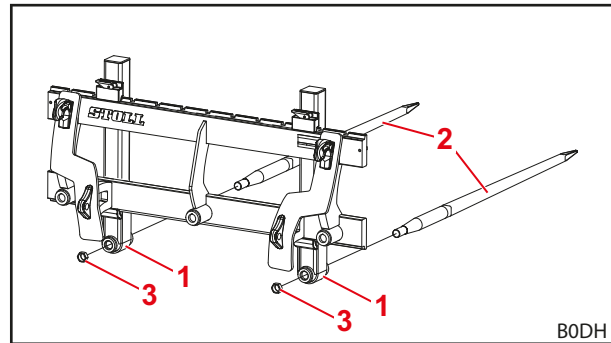

Fig. 36 Installing the bale tines on the frame parts

Legend

- 1 Frame part
- 2 Bale tines
- 3 Castle nut

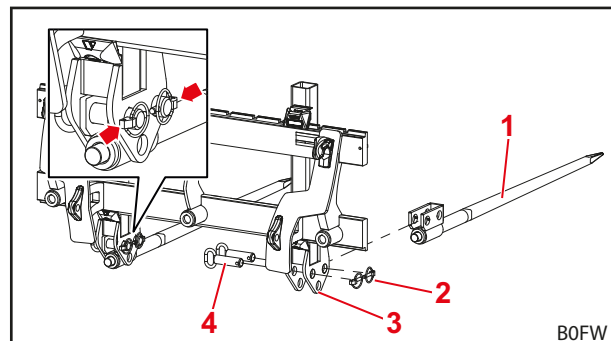

Fig. 37 Installing the bale tines on the frame parts

Legend

- 1 Bale tines
- 2 Linch pin
- 3 Frame part
- 4 Plug

(12) Switch on the tractor.

(13) Carefully move the implement to all of the end positions to ensure that it works without collisions.

- ✓ The bale tines are installed on the frame.

3.4.2.2 Check before each start-up

- see 3.1.2.2 Check before each start-up

3.4.2.3 Mounting the implement

The implement is intended for mounting on a Euro change frame.

- In doing so, observe the description and warnings for mounting implements and operation of the implement locking mechanism in the front loader operating instructions.

3.4.3 Operation

Picking up and unloading loads:

➔ Before beginning operation, check that the implement functions properly and safely without a load.

- (1) Position the implement horizontally.
- (2) Lower the front loader until the implement is positioned about in the middle in front of the large bale.
- (3) Slowly drive the tractor forwards and drive into the bale with the implement until the bale touches the frame of the implement.

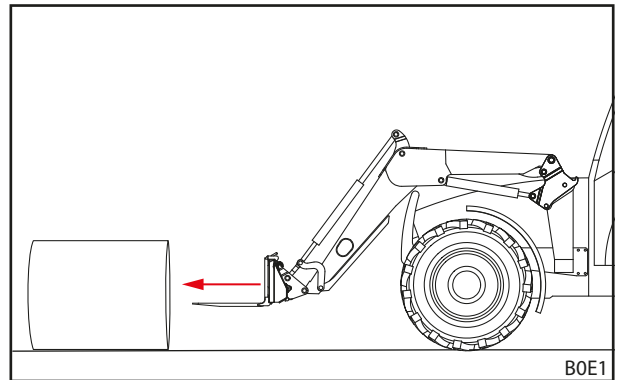

Fig. 38 Driving into the bale

- (4) Lift the load.

i Lift the load only as high as necessary for transport.

- (5) Drive the load to the target site.
 - (6) Put down the load and carefully drive out of the bale.
- ✓ The load has been picked up and unloaded.

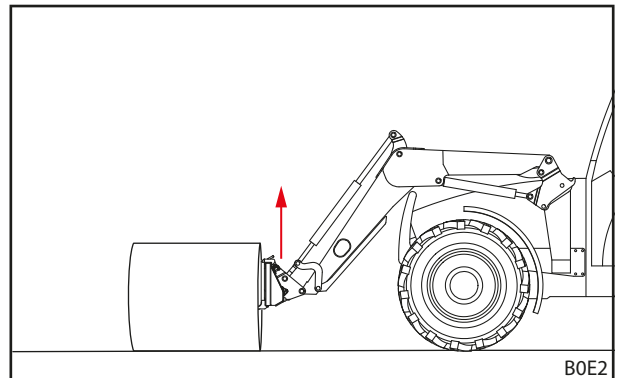

Fig. 39 Lifting the load

Operating the foldable bale tines

Folding up the bale tine:

- (1) Lower the front loader just above the ground.
- (2) Switch off the tractor.
 - Apply the parking brake.
 - Stop the engine.
- (3) Hold onto the bale tine.

i Hold onto the bale tine during the entire procedure.

- (4) Remove the linch pin and the connector from the top rear hole.
 - (5) Fold up the bale tine.
 - (6) Lock the bale tine with the linch pin and connector in the bottom hole.
- ✓ The bale tine is folded up.

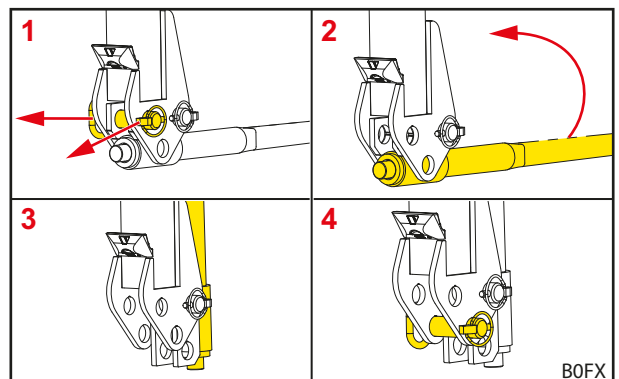

Fig. 40 Folding up the bale tine

i To fold down the bale tine, proceed in the reverse order. Hold onto the bale tine during the entire procedure.

3.4.4 Putting down the implement

- see 6.1 Temporary decommissioning

3.5 Locking grate HS

3.5.1 Structure and description

The implement consists of the following components:

- 1 locking grate

The locking grate enables securing of the load to the rear and can be used both with pallet forks HD and with large bale forks HS.

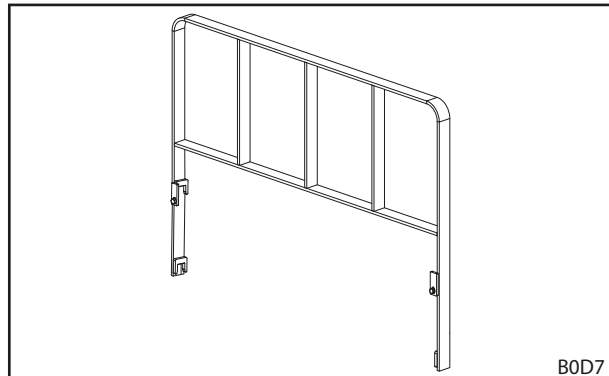

Fig. 41 Structure of the locking grate HS

3.5.2 Start-up

3.5.2.1 Check before each start-up

- See chapter "Check before each start-up" for the implement on which this accessory is installed.

3.5.2.2 Mounting the implement

Installing the locking grate on the implement:

- (1) Lower the front loader just above the ground.
- (2) Switch off the tractor.
 - Stop the engine.
 - Apply the parking brake.
- (3) Remove the hexagonal screw M10x25 on the right and left at the end of the implement profile.



The hexagonal screw M10x25 is no longer required when using the locking grate.

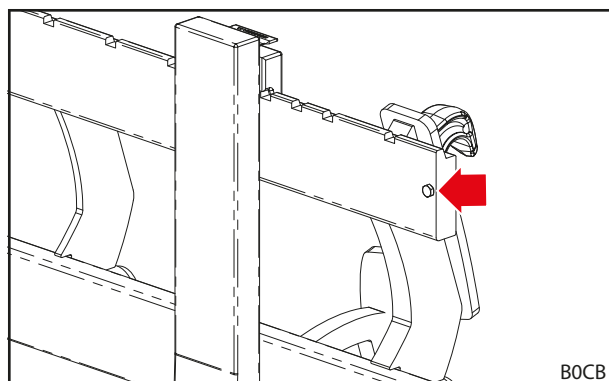

Fig. 42 Removing the hexagonal screw at the end of the profile

- (4) Slide the locking grate onto the implement frame from the top.

i Make sure that the locking grate is seated on the frame at the top and bottom (see arrows in Fig. 44).

- (5) Install the locking grate on the right and left on the frame, each with 1 hexagonal screw M10x40 and 1 detent edged ring.
- ✓ The locking grate is installed on the implement.

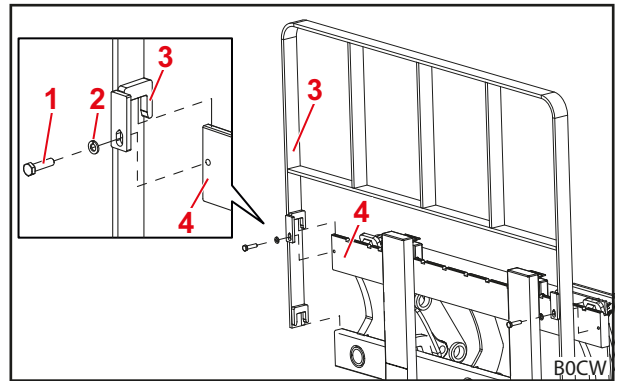

Fig. 43 Installing the locking grate on the pallet fork

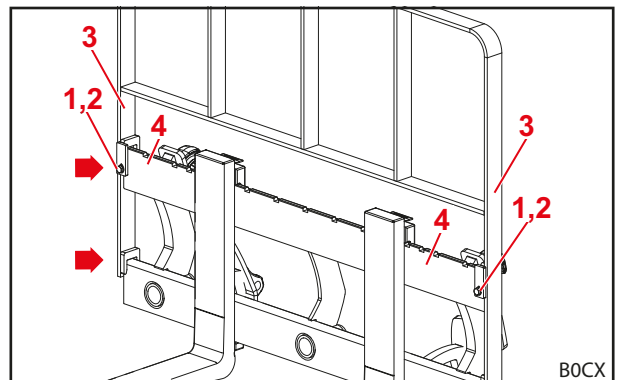

Fig. 44 Locking grate installed on the pallet fork

Legend

- 1 Hexagonal screw M10x40
- 2 Detent edged ring VSK 10
- 3 Locking grate
- 4 Beam

3.5.3 Operation

NOTICE

Material damage due to scooping too far with the implement!

When the implement is fully tilted in the scooping position, the implement can collide with the hydraulic cylinders.

This can cause damage to the implement and the front loader.

- ▶ Only scoop with the implement so far that the locking grate does not collide with the hydraulic cylinders.

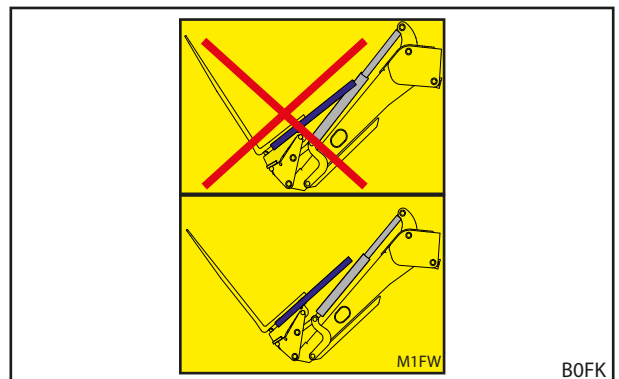

Fig. 45 Wrong (top) and right position (bottom) of the implement

3.6 Bale transport devices

3.6.1 Structure and description

The implement consists of the following components:

- Frame
- 2 bale tubes

The bale tubes are variably adjustable and each is equipped with 1 locking pin with cotter pin to latch onto the frame.

The frame and the bale tubes are each equipped with a lifting eye, on which the components can be transported (e.g. with a crane).

The frame of the bale transport device H is equipped with 2 support hooks and 2 support lugs for the Euro change frame.

The frame of the bale transport device rear is equipped with 3 locking pins for installation on the three-point hitch or on the triangle device at the rear of the tractor.

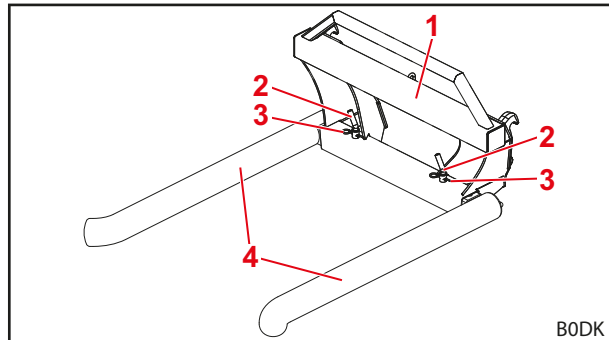

Fig. 46 Structure of bale transport device H – front view

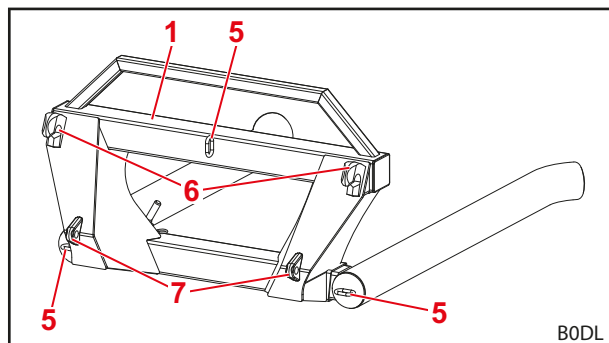

Fig. 47 Structure of bale transport device H – rear view

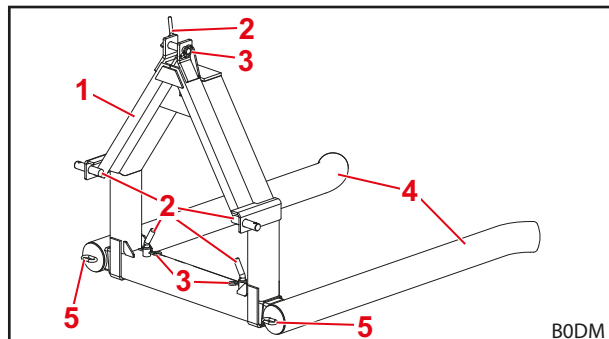

Fig. 48 Structure of bale transport device rear – rear view

Legend

- 1 Frame
- 2 Locking pin
- 3 Cotter pin
- 4 Bale tubes
- 5 Lifting eyes
- 6 Mounts for the change frame
- 7 Support lugs for pins of the change frame

3.6.2 Start-up

3.6.2.1 Initial operation

The initial operation is performed at a specialist workshop. This also includes mounting of the implement as well as a functional check.

- Obtain instruction from the specialised workshop and ask questions if necessary.
- Read the operating instructions before initial use.
- Check all of the implement functions without a load.
- Check proper functioning of the implement under all operating states.

⚠ WARNING

Risk of injury due to implements falling down!

The implement may fall down if the implement locking mechanism is open or not locked correctly. This can cause serious injury to persons standing in the surrounding area.

- ▶ Only actuate the implement locking mechanism when the implement is set down on the ground or on a secure rack.
- ▶ Always check that the implement is correctly locked.

Before initial start-up, the bale tubes must be installed on the frame.

Mounting the frame on the front loader (bale transport device H):

- (1) Lower the front loader just above the ground.
 - (2) Switch off the tractor.
 - Stop the engine.
 - Apply the parking brake.
 - (3) Lift the frame using a crane and hook onto the change frame of the front loader with the support hooks.
 - (4) Close the implement locking mechanism (see front loader operating instructions).
- ✓ The frame has been mounted on the front loader.

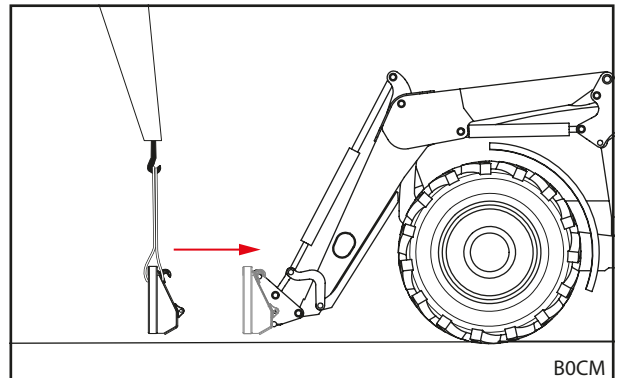

Fig. 49 Hooking the frame onto the change frame

Mounting the frame at the rear of the tractor (bale transport device rear):

- (1) Switch off the tractor.
 - Stop the engine.
 - Apply the parking brake.
- (2) Lift the frame using a crane.
- (3) Remove the upper cotter pin and locking pin.

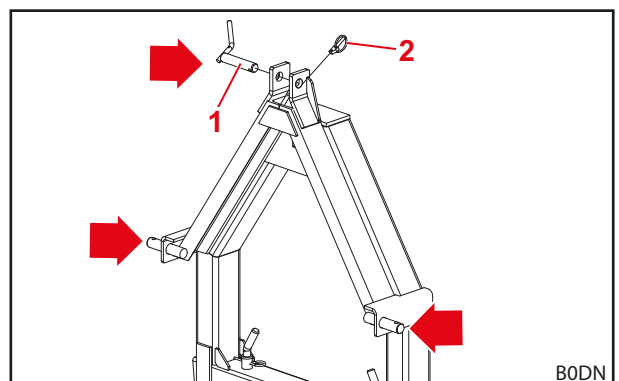

Fig. 50 Fastening points for mounting at the rear of the tractor

Legend

- 1 Locking pin
- 2 Cotter pin

- (4) Hook the frame on the three-point hitch or triangle device at the rear of the tractor.
- (5) Fasten the frame with locking pins and cotter pins.
- ✓ The frame has been mounted at the rear of the tractor.

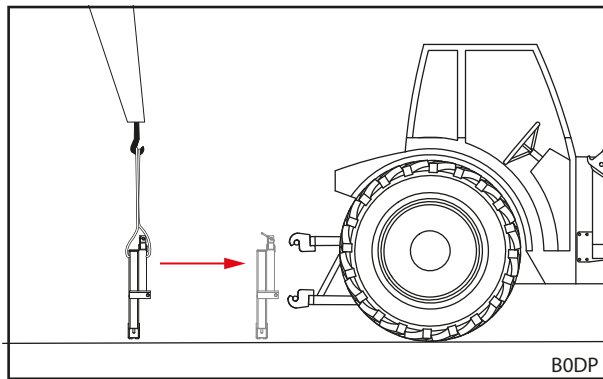

Fig. 51 Mounting the frame at the rear of the tractor

Installing the bale tubes on the frame:

- (1) Remove the lower cotter pin and locking pin.
- (2) Slide the left bale tube onto the frame from the side.
- (3) Lock the bale tube in the desired position with the locking pin.
 - Slide the bale tube to the desired position.
 - Insert the locking pin.
 - Secure the locking pin with the cotter pin.
- (4) Install the right bale tube in the same way.

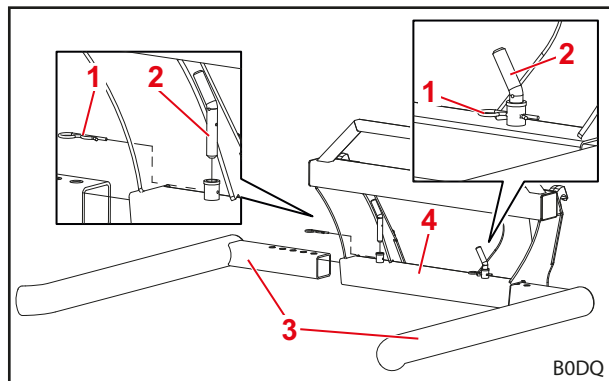

Fig. 52 Installing the bale tubes on the frame

Legend

- 1 Cotter pin
- 2 Locking pin
- 3 Bale tubes
- 4 Frame

- (5) Switch on the tractor.
- (6) For bale transport device H:
Carefully move the implement to all of the end positions to ensure that it works without collisions.
- ✓ The bale tubes are installed on the frame.

3.6.2.2 Check before each start-up

- see 3.3.2.2 *Check before each start-up*

3.6.2.3 Mounting the implement

Bale transport device H

The implement is intended for mounting on a Euro change frame.

- In doing so, observe the description and warnings for mounting implements and operation of the implement locking mechanism in the front loader operating instructions.

Bale transport device rear

i The implement is only intended for Category 2 mounting.

Mounting the implement at the rear of the tractor:

(1) Remove the upper cotter pin and locking pin.

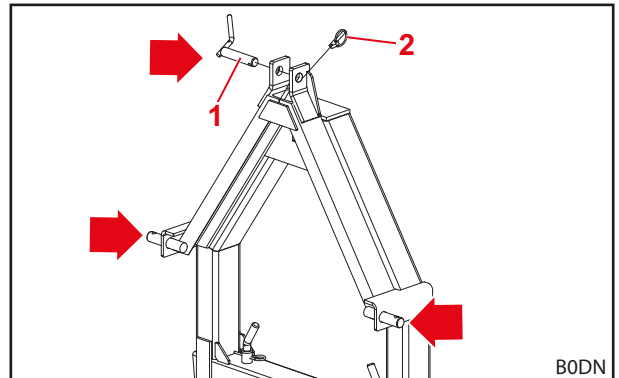

Fig. 53 Fastening points for mounting at the rear of the tractor

Legend

- 1 Locking pin
- 2 Cotter pin

- (2) Drive in reverse towards the implement.
- (3) Switch off the tractor.
 - Stop the engine.
 - Apply the parking brake.
- (4) Hook the implement on the three-point hitch or triangle device at the rear of the tractor.
- (5) Secure the implement with locking pins and cotter pins.
- ✓ The implement has been mounted at the rear of the tractor.

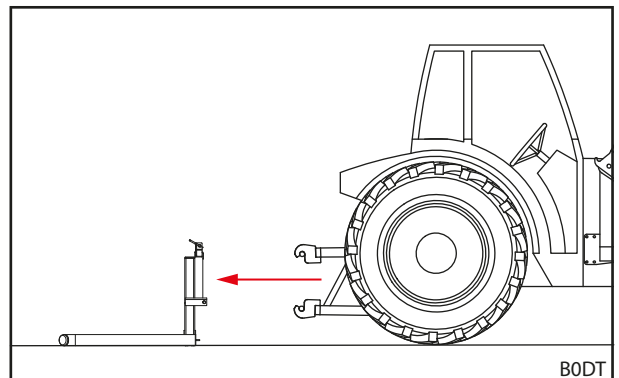

Fig. 54 Mounting the frame at the rear of the tractor

i For removal, proceed in the reverse order. Secure the implement against falling over before removing the locking pins and cotter pins!

3.6.3 Operation

i Operation is described based on the example of the bale transport device H. The bale transport device rear is operated in the same way, only that the bales are picked up in reverse at the rear.

Picking up and unloading loads:

➔ Before beginning operation, check that the implement functions properly and safely without a load.

- (1) If necessary, adjust the spacing of the bale tubes for the width of the bale to be transported (see 3.6.2.1 *Initial operation*).
- (2) Lower the front loader until it is just above the ground and position the implement horizontally.
- (3) Carefully drive into the bale with the bale tubes.

i In doing so, the bale tubes grasp the bale.

- (4) Lift the load.

i Lift the load only as high as necessary for transport.

- (5) Drive the load to the target site.
 - (6) Put down the load and carefully drive out of the bale.
- ✓ The load has been picked up and unloaded.

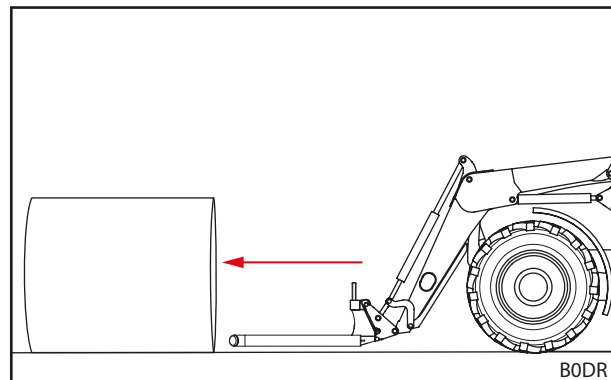

Fig. 55 Driving into the bale

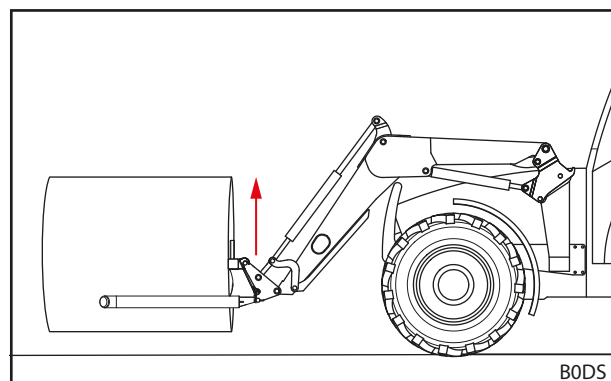

Fig. 56 Lifting the load

3.6.4 Putting down the implement

3.6.4.1 Bale transport device H

➤ see 6.1 *Temporary decommissioning*

3.6.4.2 Bale transport device rear

➤ see *Bale transport device rear*

3.7 Bale spikes

3.7.1 Structure and description

The implement consists of the following components:

- 1 frame
- 2 bale tines (size depending on the model)
- 4-6 tine sockets

Depending on the model, the frame can be equipped with 4-6 tine sockets for installing bale tines. The bale tines can be variably positioned.

For bale spikes H and Global, the frame is equipped with 2 support hooks and 2 support lugs for the Euro change frame.

For bale spikes Skid, the frame is equipped with 2 mounts for the skid-steer change frame.

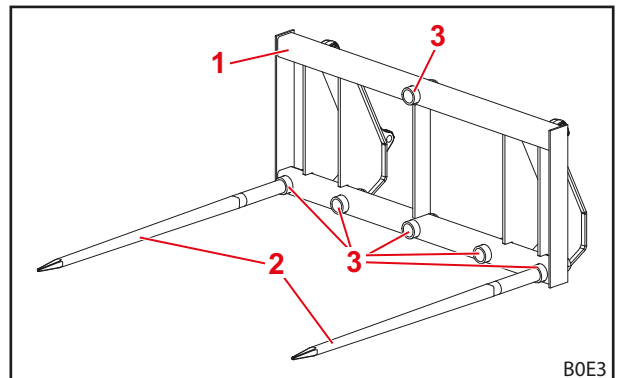

Fig. 57 Structure of bale spike H – front view

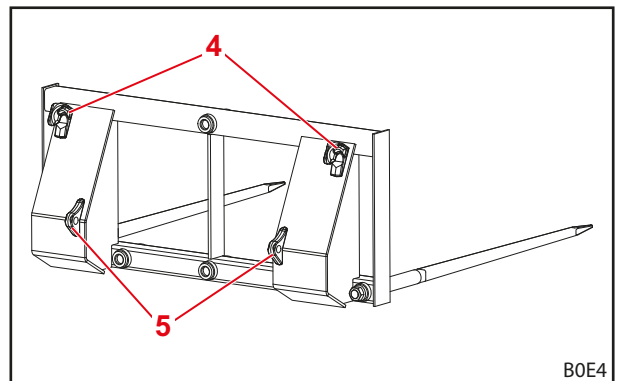

Fig. 58 Structure of bale spike H – rear view

Legend

- 1 Frame
- 2 Bale tines
- 3 Tine sockets
- 4 Mounts for the change frame
- 5 Support lugs for pins of the change frame

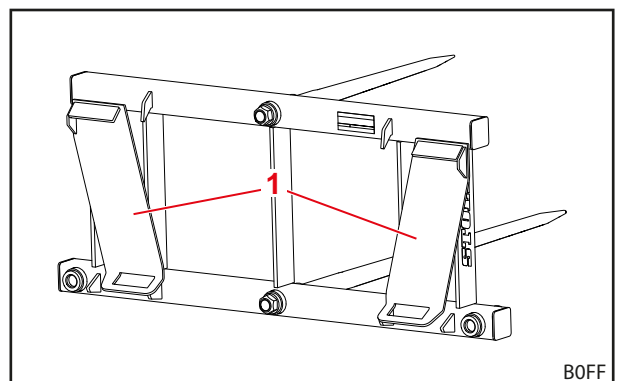

Fig. 59 Structure of bale spike Skid – rear view

Legend

- 1 Mounts for the change frame

3.7.2 Start-up

3.7.2.1 Initial operation

The initial operation is performed at a specialist workshop. This also includes mounting of the implement as well as a functional check.

- Obtain instruction from the specialised workshop and ask questions if necessary.
- Read the operating instructions before initial use.
- Check all of the implement functions without a load.
- Check proper functioning of the implement under all operating states.

⚠ WARNING

Risk of injury due to implements falling down!

The implement may fall down if the implement locking mechanism is open or not locked correctly. This can cause serious injury to persons standing in the surrounding area.

- ▶ Only actuate the implement locking mechanism when the implement is set down on the ground or on a secure rack.
- ▶ Always check that the implement is correctly locked.

Before initial start-up, the bale tines must be installed on the frame.

Installing the bale tines on the frame:

- ✂ Open-ended spanner 41 mm WAF
 - ✂ Torque wrench
- (1) Lower the front loader just above the ground.
 - Stop the engine.
 - Apply the parking brake.
 - (2) Switch off the tractor.
 - (3) Lift the frame using a crane and hook onto the change frame of the front loader with the support hooks.
 - (4) Close the implement locking mechanism (see front loader operating instructions).

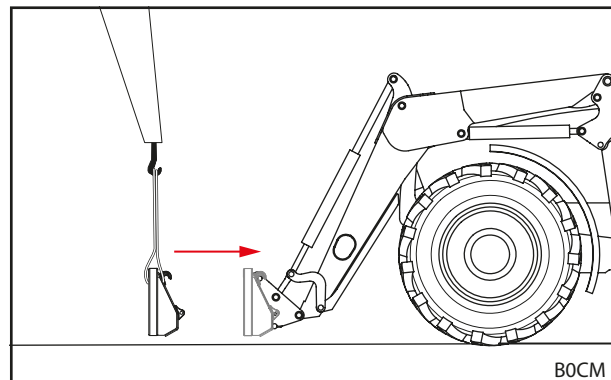

Fig. 60 Hooking the frame onto the change frame

- (5) Remove the conical nut from the first bale tine.
- (6) Insert the bale tine through the tine socket and fasten on the other side with the conical nut.



Tightening torque: 1840 Nm

- (7) Install the second bale tine in the same way.



Fig. 61 shows an example. The tine sockets can be chosen freely.

- (8) Switch on the tractor.
 - (9) Carefully move the implement to all of the end positions to ensure that it works without collisions.
- ✓ The bale tines are installed on the frame.

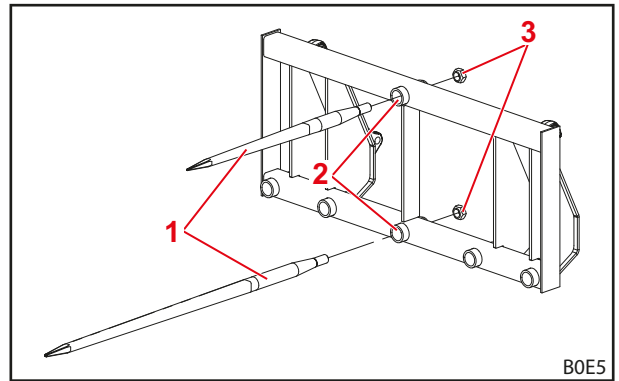

Fig. 61 Installing the bale tines on the frame

Legend

- 1 Bale tines
- 2 Tine sockets
- 3 Conical nut

3.7.2.2 Check before each start-up

- see 3.1.2.2 *Check before each start-up*

3.7.2.3 Mounting the implement

Bale spikes H and Global are intended for mounting on a Euro change frame.

The bale spike Skid is intended for mounting on a skid-steer change frame.

- In doing so, observe the description and warnings for mounting implements and operation of the implement locking mechanism in the front loader operating instructions.

3.7.3 Operation

- see 3.4.3 *Operation*

3.7.4 Putting down the implement

- see 6.1 *Temporary decommissioning*

3.8 Manure forks

3.8.1 Structure and description

The implement consists of the following components:

- 1 frame
- 7-14 fork tines (number depends on the model)

The frame is equipped with a lifting eye at the top rear, on which the implement can be transported (e.g. with a crane).

The frame is equipped with 2 support hooks and 2 support lugs for the Euro change frame.

Manure forks for FZ 60/60.1/80.1/100 front loaders (ID numbers 3611820, 3611830, 3611930, 3660460) are additionally equipped with 2 brackets for an optional loading grid.

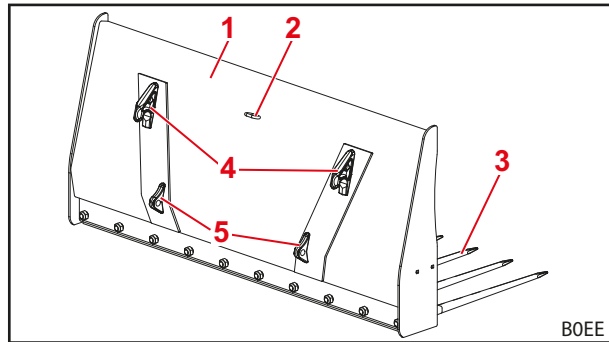

Fig. 62 Structure of the manure fork – rear view

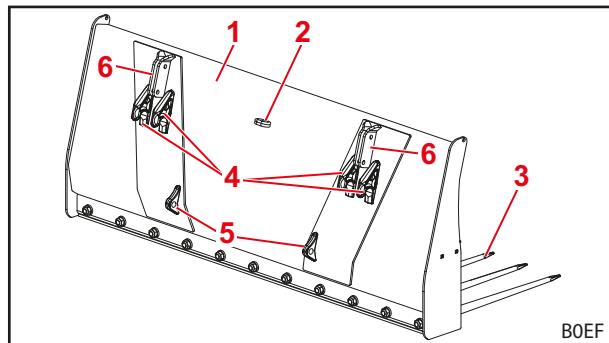

Fig. 63 Structure of the manure fork (for FZ 60/60.1/80.1/100 front loaders) – rear view

Legend

- 1 Frame
- 2 Lifting eye
- 3 Fork arms
- 4 Support hooks for change frame
- 5 Support lugs for pins of the change frame
- 6 Brackets for the loading grid

As an option, the manure fork can be additionally equipped with 2 side tines that secure the load towards the sides.

Manure forks for FZ 60/60.1/80.1/100 front loaders (ID numbers 3611820, 3611830, 3611930, 3660460) can be optionally equipped with a loading grid that enables securing of the load towards the rear.

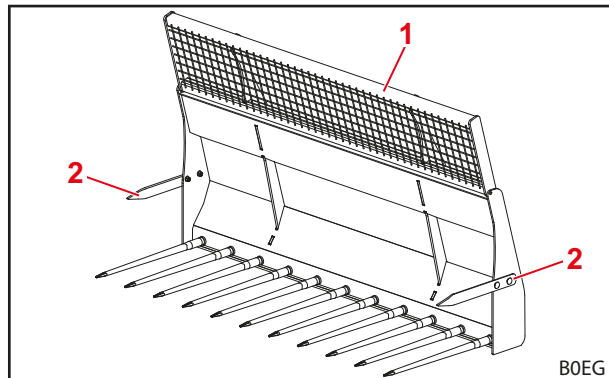

Fig. 64 Manure fork with side tines and loading grid

Legend

- 1 Loading grid (optional, only for FZ 60/60.1/80.1/100 front loaders)
- 2 Side tines (optional)

3.8.2 Start-up

3.8.2.1 Initial operation

The initial operation is performed at a specialist workshop. This also includes mounting of the implement as well as a functional check.

- Obtain instruction from the specialised workshop and ask questions if necessary.
- Read the operating instructions before initial use.
- Check all of the implement functions without a load.
- Check proper functioning of the implement under all operating states.

⚠ WARNING

Risk of injury due to implements falling down!

The implement may fall down if the implement locking mechanism is open or not locked correctly. This can cause serious injury to persons standing in the surrounding area.

- ▶ Only actuate the implement locking mechanism when the implement is set down on the ground or on a secure rack.
- ▶ Always check that the implement is correctly locked.

Before initial start-up, the fork tines and, if equipped, optional accessories must be installed.

Installing the frame:

- (1) Lower the front loader just above the ground.
 - (2) Switch off the tractor.
 - Stop the engine.
 - Apply the parking brake.
 - (3) Lift the frame using a crane and hook onto the change frame of the front loader with the support hooks.
 - (4) Close the implement locking mechanism (see front loader operating instructions).
- ✓ The frame is installed.

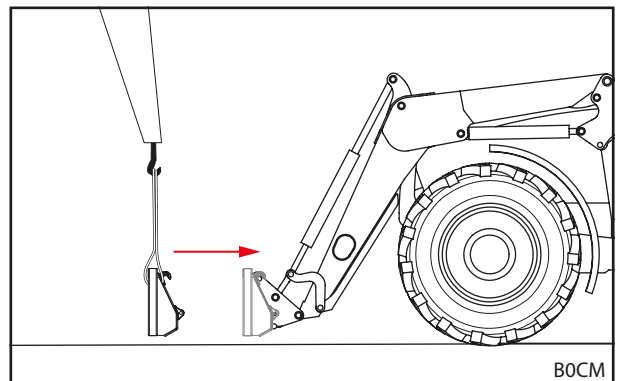



Fig. 65 Hooking the frame onto the change frame

Installing the fork tines on the frame:

- ✘ Open-ended spanner 41 mm WAF
- ✘ Torque wrench
- (5) Remove the conical nut from the first fork tine.
- (6) Insert the fork tine through the tine socket and fasten on the other side with the conical nut.

 Tightening torque: 870 Nm

- (7) Install the remaining fork tines in the same way.
- ✓ The fork tines are installed on the frame.

Installing the loading grid on the frame:

- (8) Install the loading grid on the brackets, each with 2 hexagonal screws M12x50 and hexagonal nuts.
- ✓ The loading grid is installed on the frame.

Installing the side tines on the frame:

- (9) Install the side tines on the right and left of the frame, each with 2 truss head screws M12x35, washers, and hexagonal nuts.
- ✓ The side tines are installed on the frame.

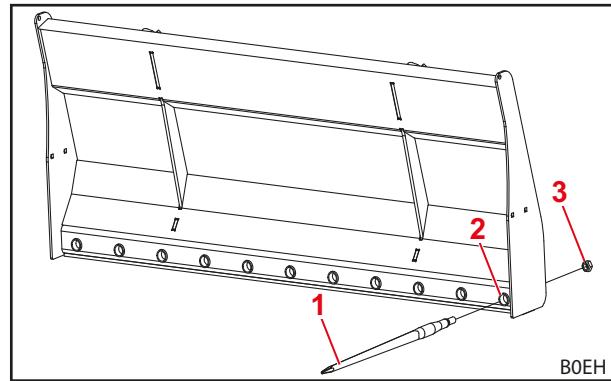

Fig. 66 Installing the fork tines on the frame

Legend

- 1 Fork arms
- 2 Tine sockets
- 3 Conical nut

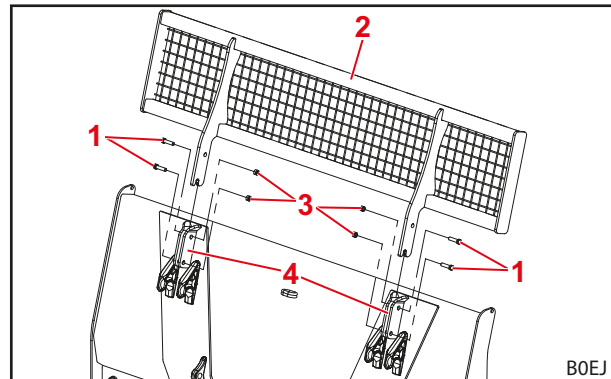

Fig. 67 Installing the loading grid on the frame

Legend

- 1 Brackets for the loading grid
- 2 Loading grid
- 3 Hexagonal screws M12x50
- 4 Hexagonal nuts M12

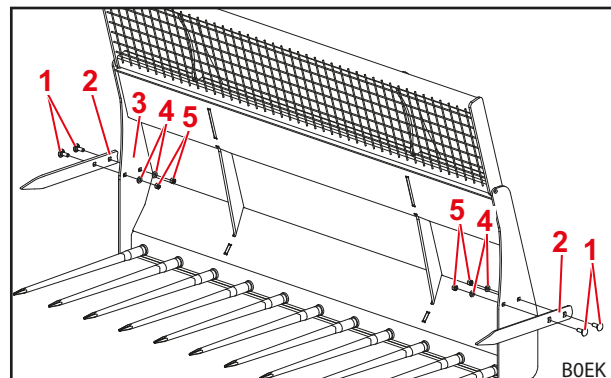

Fig. 68 Installing the side tines on the frame

Legend

- 1 Truss head screws M12x35
- 2 Side tines
- 3 Beam
- 4 Washers A13
- 5 Hexagonal nuts M12

- (10) Switch on the tractor.
- (11) Carefully move the implement to all of the end positions to ensure that it works without collisions.
- ✓ Initial start-up has been prepared.

3.8.2.2 Check before each start-up

- see 3.1.2.2 *Check before each start-up*

3.8.2.3 Mounting the implement

The implement is intended for mounting on a Euro change frame.

- In doing so, observe the description and warnings for mounting implements and operation of the implement locking mechanism in the front loader operating instructions.

3.8.3 Operation

Picking up and unloading loads:

➔ Before beginning operation, check that the implement functions properly and safely without a load.

- (1) Lower the front loader to the desired height.
- (2) Position the implement horizontally.
- (3) Drive straight into the manure pile with the fork tines.

 For big piles, take the material from the top.

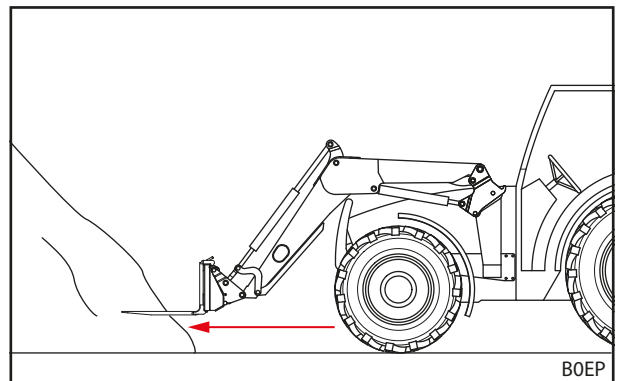

Fig. 69 *Driving into the manure pile*

- (4) Tilt the implement and/or lift the front loader.
- (5) Drive away from the load in reverse.
- (6) Drive the load to the target site.
- (7) Unload the load from the implement with the *dumping* function.
- ✓ The load has been picked up and unloaded.

3.8.4 Putting down the implement

- see 6.1 *Temporary decommissioning*

3.9 Log fork H

3.9.1 Structure and description

The implement consists of the following components:

- 1 log fork body

The log fork body is equipped with a lifting eye at the top rear, on which the implement can be transported (e.g. with a crane).

The rear side of the log fork body is equipped with 2 support hooks and 2 support lugs for the Euro change frame.

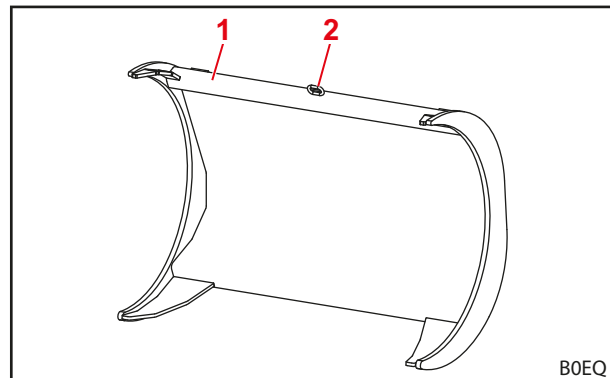

Fig. 70 Structure of log fork H- front view

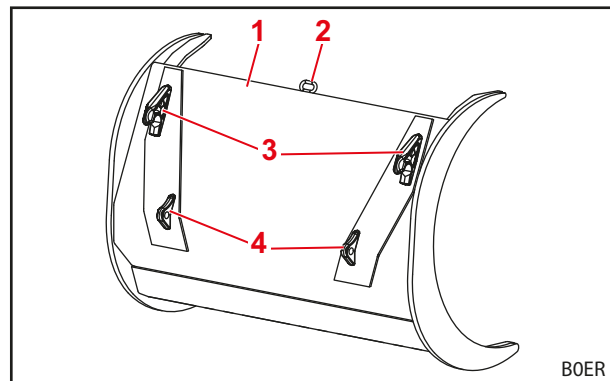

Fig. 71 Structure of log fork H- rear view

Legend

- 1 Log fork body
- 2 Lifting eye
- 3 Support hooks for change frame
- 4 Support lugs for pins of the change frame

3.9.2 Start-up

3.9.2.1 Initial operation

The initial operation is performed at a specialist workshop. This also includes mounting of the implement as well as a functional check.

- Obtain instruction from the specialised workshop and ask questions if necessary.
- Read the operating instructions before initial use.
- Check all of the implement functions without a load.
- Check proper functioning of the implement under all operating states.

3.9.2.2 Check before each start-up

- see 3.3.2.2 *Check before each start-up*

3.9.2.3 Mounting the implement

The implement is intended for mounting on a Euro change frame.

- In doing so, observe the description and warnings for mounting implements and operation of the implement locking mechanism in the front loader operating instructions.

3.9.3 Operation

Pushing the tree trunks together:

- ➔ Before beginning operation, check that the implement functions properly and safely without a load.
- (1) Lower the front loader until it is just above the ground and position the implement vertically.
 - (2) Slowly drive forwards and push the tree trunks together.
- ✓ The tree trunks have been pushed together.

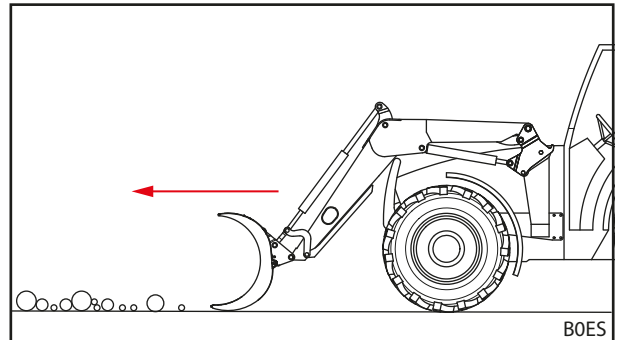

Fig. 72 Pushing tree trunks together

Picking up and loading tree trunks:

- ➔ Before beginning operation, check that the implement functions properly and safely without a load.
- (1) Lower the front loader until it is just above the ground and position the implement vertically.
 - (2) Slowly drive forwards and push the tree trunks together.

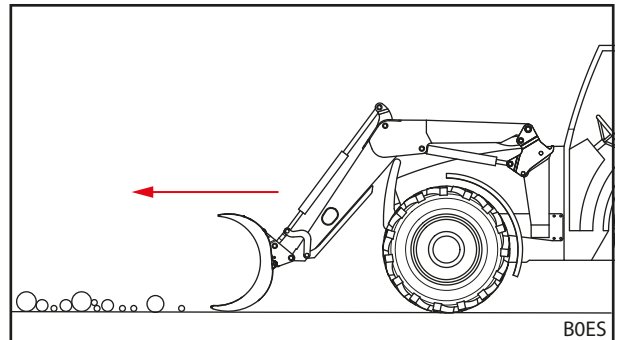

Fig. 73 Pushing tree trunks together

- (3) Tip the implement to the rear with the *scooping* function.
- (4) Lift the load.

i Lift the load only as high as necessary for transport.

- (5) Drive the load to the target site.
 - (6) Unload the load from the implement with the *dumping* function.
- ✓ The tree trunks have been picked up and loaded.

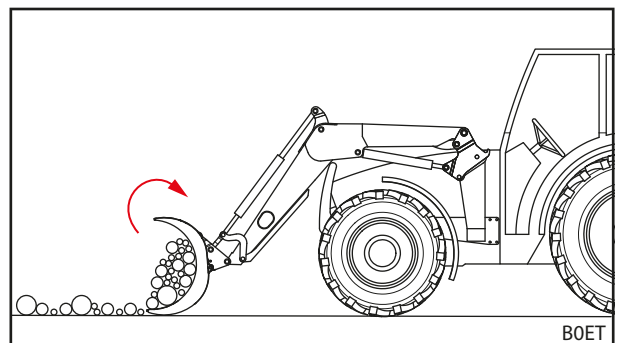

Fig. 74 Tipping the implement to the rear

3.9.4 Putting down the implement

⚠ CAUTION

Risk of injury due to implement tipping over!

When the implement is put down in a upright position, it will tip over. This can cause injuries to persons standing in the surrounding area.

- ▶ Always put down the log fork H on the tips of the log fork body.
- ▶ For mounting on the front loader, swivel the change frame far to the front.

➤ see 6.1 *Temporary decommissioning*

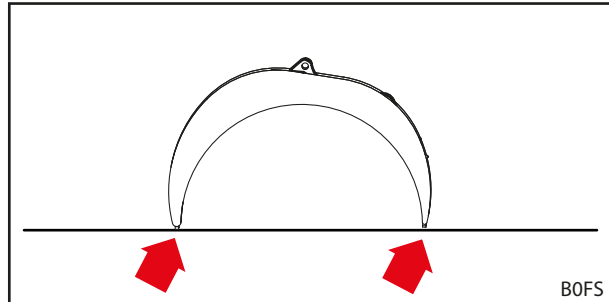

Fig. 75 Putting down the implement

3.10 Bigbag lifter

3.10.1 Structure and description

The implement consists of the following components:

- 1 frame
- 1 oscillation limiter
- 1 arm
- 1 support hook for the loop(s) of the Bigbag

The frame is equipped with 2 support hooks and 2 support lugs for the Euro change frame.

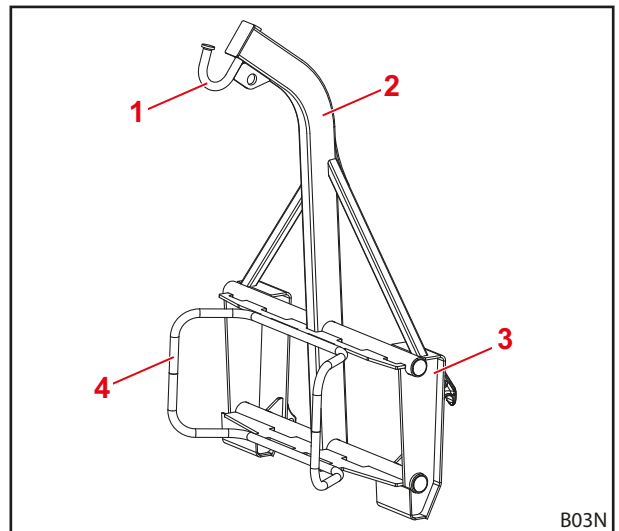

Fig. 76 Structure of Bigbag lifter– front view

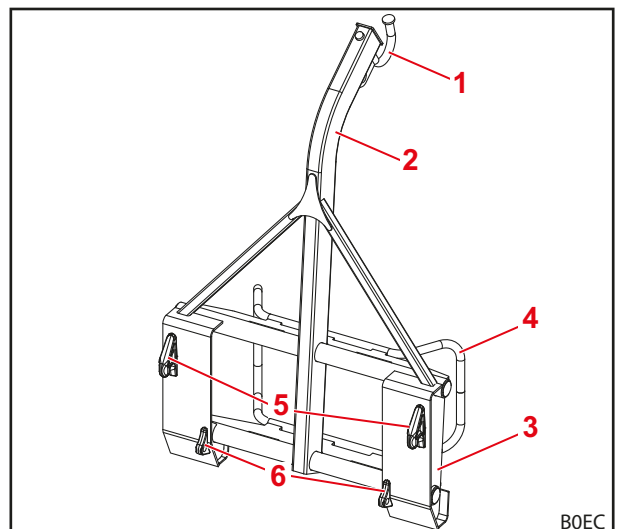

Fig. 77 Structure of Bigbag lifter– rear view

Legend

- 1 Support hook for the loop(s) of the Bigbag
- 2 Arm
- 3 Frame
- 4 Oscillation limiter
- 5 Mounts for the change frame
- 6 Support lugs for pins of the change frame

3.10.2 Start-up

3.10.2.1 Initial operation

The initial operation is performed at a specialist workshop. This also includes mounting of the implement as well as a functional check.

- Obtain instruction from the specialised workshop and ask questions if necessary.
- Read the operating instructions before initial use.
- Check all of the implement functions without a load.
- Check proper functioning of the implement under all operating states.

3.10.2.2 Check before each start-up

- see 3.3.2.2 *Check before each start-up*

3.10.2.3 Mounting the implement

CAUTION

Risk of injury due to implement tipping over!

When the implement is put down in a upright position, it will tip over. This can cause injuries to persons standing in the surrounding area.

- ▶ Always put down the Bigbag lifter on the oscillation limiter and the support hook.
- ▶ For mounting on the front loader, swivel the change frame all the way to the front.

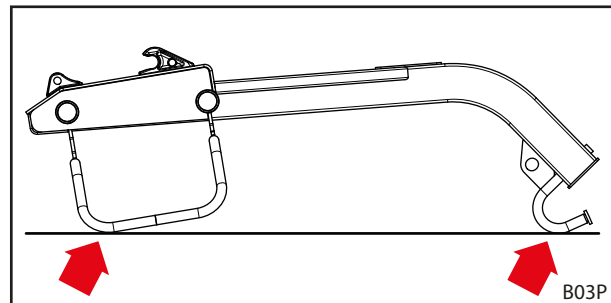

Fig. 78 Putting down the implement

The implement is intended for mounting on a Euro change frame.

- In doing so, observe the description and warnings for mounting implements and operation of the implement locking mechanism in the front loader operating instructions.

3.10.3 Operation

⚠ WARNING

Risk of injury due to unexpected lowering of the front loader when the load sways!

If the Bigbag lifter is swivelled too far to the front with the load, the pressure relief valve of the front loader or the tractor can be triggered. The front loader is then suddenly lowered. This can cause serious injuries to persons standing in the surrounding area.

- ▶ Pick up the Bigbag without a helper.
- ▶ Immediately after picking up the Bigbag, swivel the Bigbag lifter up (*scooping function* of the front loader), so that the Bigbag is within the oscillation limiter.
- ▶ Do not use the Bigbag lifter as a substitute for a crane.

⚠ WARNING

Lethal danger due to oscillation of the Bigbag while driving!

The Bigbag can oscillate if the position of the implement is unsuitable or when driving too fast. This can cause unstable driving behaviour or even tipping over of the tractor. The driver and persons standing in the surrounding area can be seriously injured or even killed.

- ▶ Do not drive faster than 6 km/h so that the Bigbag does not start oscillating.
- ▶ Before driving, swivel the implement far enough to the rear so that the Bigbag is securely resting on the oscillation limiter, even on uneven ground.
- ▶ Do not swivel the implement forwards while driving.



Fig. 79 Correct (left) and unsuitable position (right) of the implement

Picking up and unloading the load:

➔ Before beginning operation, check that the implement functions properly and safely without a load.

- (1) Lower the front loader just above the ground.
- (2) Swivel the implement to the front so that the support hook is at the same height as the loops of the Bigbag.
- (3) Carefully drive forwards until the support hook grasps the loop.

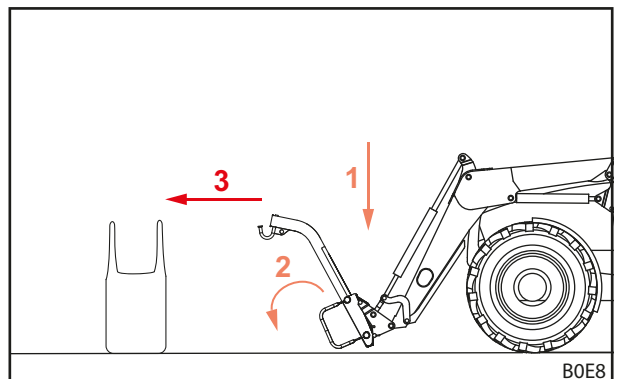

Fig. 80 Implement swivelled to the front

- (4) Swivel up the implement a bit so that the loops are slightly taut.
- (5) Check whether the loops are correctly seated in the support hook.

i If the loops are not correctly seated in the support hook, repeat the previous steps.

- (6) Swivel the implement further up until the Bigbag is resting against the oscillation limiter.

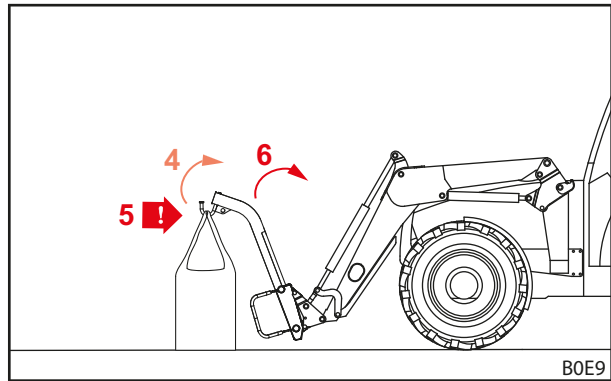

Fig. 81 Slightly taut loops

- (7) Lift the load.

i Lift the load only as high as necessary for transport.

- (8) Drive the load to the target site.

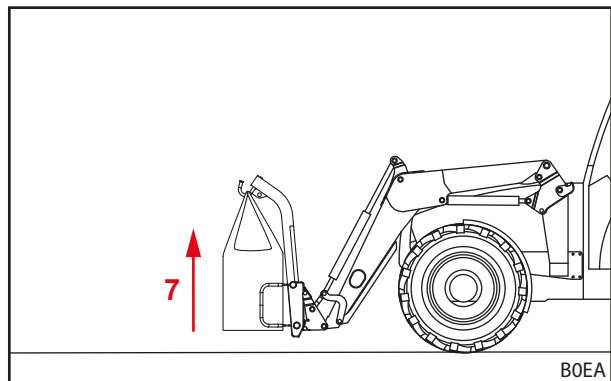

Fig. 82 Lifting the load

- (9) Lower the front loader just above the ground.
- (10) Swivel the implement to the front until the Bigbag is standing firmly on the ground and the loops are hanging loosely.
- (11) Slowly drive in reverse until the support hook is completely released from the loops.
- (12) Position the implement horizontally again.
 - ✓ The load has been picked up and unloaded.

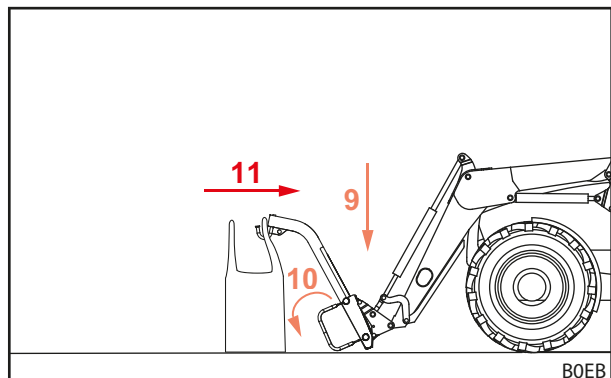

Fig. 83 Slowly driving in reverse

3.10.4 Putting down the implement

⚠ CAUTION

Risk of injury due to implement tipping over!

When the implement is put down in a upright position, it will tip over. This can cause injuries to persons standing in the surrounding area.

- ▶ Always put down the Bigbag lifter on the oscillation limiter and the support hook.
- ▶ For mounting on the front loader, swivel the change frame all the way to the front.

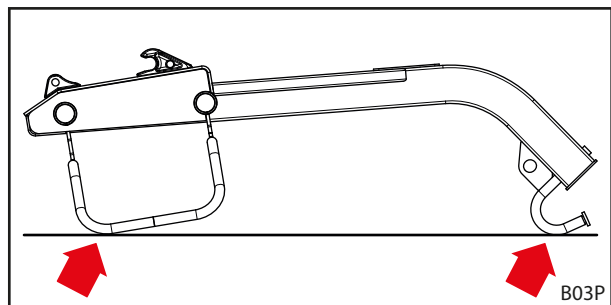

Fig. 84 Putting down the implement

- see 6.1 Temporary decommissioning

3.11 Bag-Lift H

3.11.1 Structure and description

The implement consists of the following components:

- 1 frame
- 2 arm
- 4 support hooks for the 4 loops of the Bigbag

The frame is equipped with 2 support hooks and 2 support lugs for the Euro change frame.

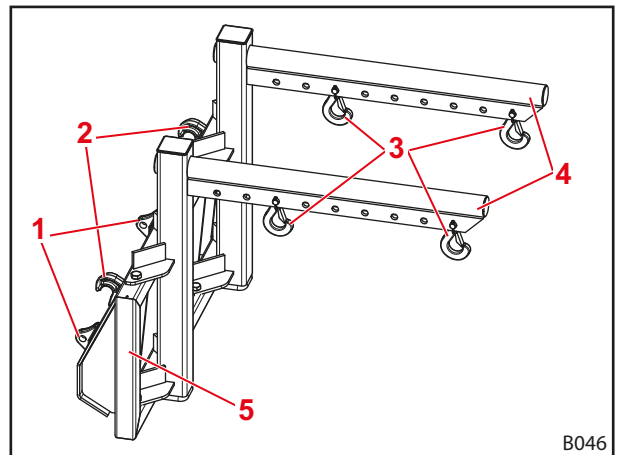

Fig. 85 Structure of the Bag-Lift H

Legend

- 1 Support lugs for pins of the change frame
- 2 Support hooks for change frame
- 3 Support hook for the loop of the Bigbag
- 4 Arm
- 5 Frame

3.11.2 Start-up

3.11.2.1 Initial operation

The initial operation is performed at a specialist workshop. This also includes mounting of the implement as well as a functional check.

- Obtain instruction from the specialised workshop and ask questions if necessary.
- Read the operating instructions before initial use.
- Check all of the implement functions without a load.
- Check proper functioning of the implement under all operating states.

3.11.2.2 Check before each start-up

- see 3.3.2.2 *Check before each start-up*

3.11.2.3 Mounting the implement

⚠ CAUTION

Risk of injury due to implement tipping over!

When the implement is put down in a upright position, it will tip over. This can cause injuries to persons standing in the surrounding area.

- ▶ Always put down the bag-lift on the frame and both arms.
- ▶ For mounting on the front loader, swivel the change frame far to the front.

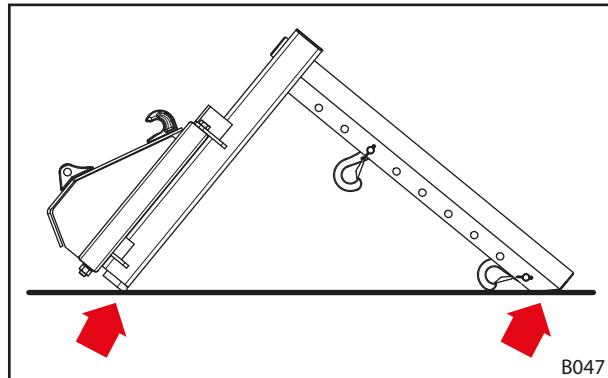

Fig. 86 Putting down the implement

The implement is intended for mounting on a Euro change frame.

- In doing so, observe the description and warnings for mounting implements and operation of the implement locking mechanism in the front loader operating instructions.

3.11.3 Operation

⚠ WARNING

Risk of injury and death due to oscillation of the load while driving!

The load can oscillate when driving too fast. This can cause unstable driving behaviour or even tipping over of the tractor. The driver and persons standing in the surrounding area can be seriously injured or even killed.

- ▶ Drive particularly slowly.
- ▶ Watch the load while driving and stop if the load starts oscillating.

⚠ WARNING

Risk of injury due to unexpected lowering of the front loader!

If the front loader is suddenly lowered, people in the work area can be seriously injured.

- ▶ Pick up the load without a helper.
- ▶ Only hook on the load on the hooks when the front loader is completely lowered.
- ▶ If a load should be hooked on when the front loader is lifted, the front loader must be equipped with an anti-lowering guard (see front loader operating instructions). The anti-lowering guard has to correspond to the European standard EN 12525/A1.
- ▶ Do not use the Bag-Lift as a substitute for a crane.

Picking up and unloading the load:

➔ Before beginning operation, check that the implement functions properly and safely without a load.

- (1) Position the implement over the Bigbag.
- (2) If there is no anti-lowering guard: Lower the front loader all the way to the ground.
- (3) Hook the 4 loops of the Bigbag onto the support hook of the implement.
- (4) Raise the implement a bit so that the loops are slightly taut.

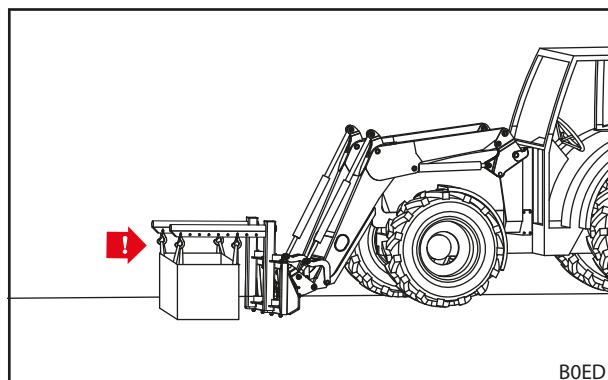

Fig. 87 Bigbag hooked onto the implement

- (5) Check whether the loops are correctly seated in the support hook.
- (6) Lift the load.

i Lift the load only as high as necessary for transport.

- (7) Drive the load to the target site.
 - (8) Lower the implement until the Bigbag is standing firmly on the ground and the loops are hanging loosely.
 - (9) If there is no anti-lowering guard: Lower the front loader all the way to the ground.
 - (10) Take the loops out of the support hook.
- ✓ The load has been picked up and unloaded.

3.11.4 Putting down the implement

⚠ CAUTION
Risk of injury due to implement tipping over!
 When the implement is put down in a upright position, it will tip over. This can cause injuries to persons standing in the surrounding area.

- ▶ Always put down the bag-lift on the frame and both arms.
- ▶ For mounting on the front loader, swivel the change frame far to the front.

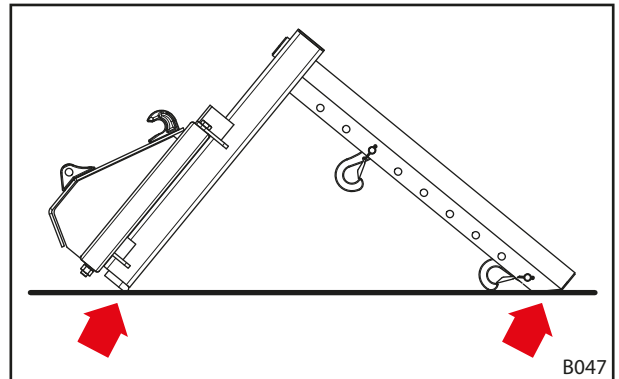

Fig. 88 Putting down the implement

➤ see 6.1 Temporary decommissioning

3.12 Load hook

3.12.1 Structure and description

The implement consists of the following components:

- 1 mount
- 2 lugs for fastening onto the implement locking mechanism of the front loader
- 1 hook

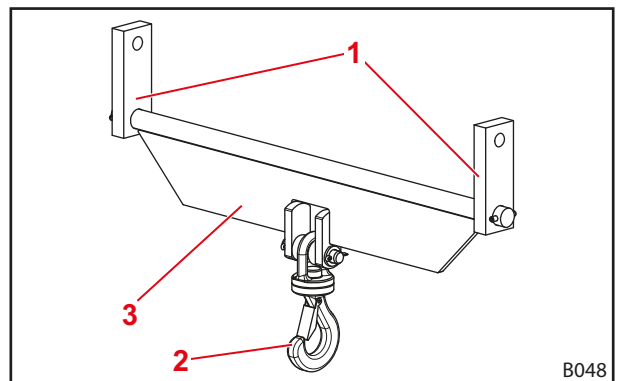

Fig. 89 Structure of the load hook

Legend

- 1 Lugs
- 2 Hook
- 3 Bracket

3.12.2 Start-up

3.12.2.1 Initial operation

The initial operation is performed at a specialist workshop. This also includes mounting of the implement as well as a functional check.

- Obtain instruction from the specialised workshop and ask questions if necessary.
- Read the operating instructions before initial use.
- Check all of the implement functions without a load.
- Check proper functioning of the implement under all operating states.

3.12.2.2 Check before each start-up

- see 3.3.2.2 *Check before each start-up*

3.12.2.3 Mounting the implement

⚠ CAUTION

Risk of crushing due to spring tension!

There is spring tension on the handle of the implement locking mechanism, which closes the locking mechanism when the handle is lifted. Improper use can lead to injury to hands and fingers.

- ▶ Always operate the handle with one hand and grab it in the middle.

The implement is intended for mounting on a Euro change frame.

- In doing so, observe the description and warnings for mounting implements and operation of the implement locking mechanism in the front loader operating instructions.

Mounting the implement:

- ➔ The Euro change frame must be laying on the ground.
- (1) Open the implement locking mechanism of the front loader (see front loader operating instructions).
- (2) Insert the lugs of the implement in the mounts on the change frame intended for locking eyes of other implements.
- (3) Close the implement locking mechanism (see front loader operating instructions).

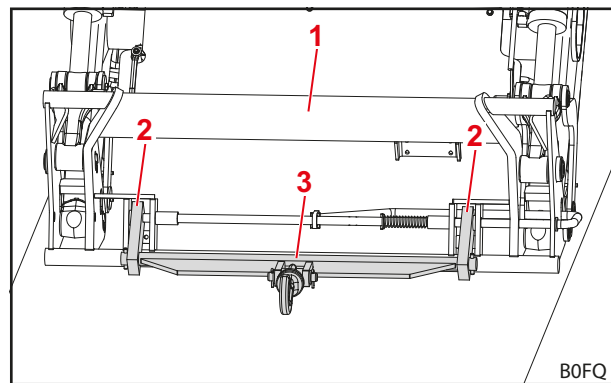

Fig. 90 Mounted implement

i The locking pins must be securely seated in the holes of the lugs.

- ✓ The implement is mounted.

Legend

- 1 Change frame
- 2 Lugs
- 3 Load hook

3.12.3 Operation

⚠ WARNING

Risk of injury due to unexpected lowering of the front loader!

If the front loader is suddenly lowered, people in the work area can be seriously injured.

- ▶ Pick up the load without a helper.
- ▶ Only hook on the load on the hook when the front loader is completely lowered.
- ▶ If a load should be hooked on when the front loader is lifted, the front loader must be equipped with an anti-lowering guard (see front loader operating instructions). The anti-lowering guard has to correspond to the European standard EN 12525/A1.
- ▶ Do not use the load hook as a substitute for a crane.

⚠ WARNING

Risk of injury and death due to oscillation of the load while driving!

The load can oscillate when driving too fast. This can cause unstable driving behaviour or even tipping over of the tractor. The driver and persons standing in the surrounding area can be seriously injured or even killed.

- ▶ Drive particularly slowly.
- ▶ Watch the load while driving and stop if the load starts oscillating.

Picking up and unloading the load:

➔ Before beginning operation, check that the implement functions properly and safely without a load.

- (1) If there is no anti-lowering guard: Lower the front loader down to the ground.
- (2) Hook the load onto the hook.
- (3) Raise the front loader until the load is hanging freely.
- (4) Position the implement so that the lugs are resting on the lower cross bar of the change frame (see Fig. 91).
- (5) Drive to the unloading site very carefully.

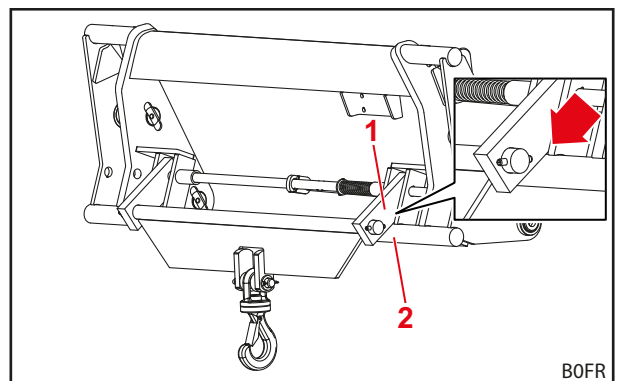

Fig. 91 Position of the implement for load transport

Legend

- 1 Lug
- 2 Lower cross bar

i The load may not start swaying.

- (6) Lower the front loader until the load is resting on the ground.
- (7) If there is no anti-lowering guard: Back up a bit and lower the front loader completely.
- (8) Unhook the load from the hook.
- ✓ The load has been picked up and unloaded.

3.12.4 Putting down the implement

- see 6.1 Temporary decommissioning

3.13 Tenias adapter

3.13.1 Structure and description

The adapter consists of the following components:

- 1 frame
- 1 locking rod
- 1 self-locking lever
- 1 cotter pin
- 2 Tenias catch hook mounts

The frame is equipped with 2 support hooks and 2 support lugs for the Euro change frame.

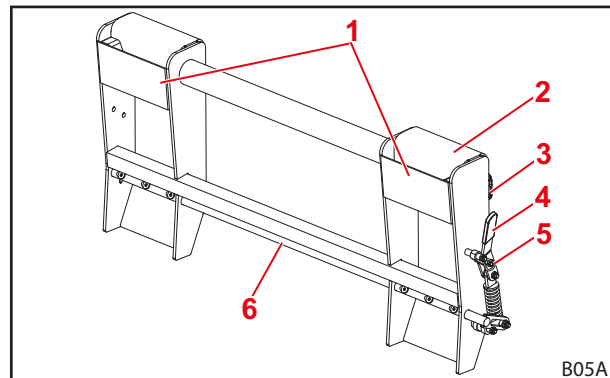

Fig. 92 Structure of the Tenias adapter

Legend

- 1 Tenias catch hook mounts
- 2 Beam
- 3 Support hooks for change frame
- 4 Locking lever
- 5 Spring cotter pin
- 6 Locking rod

3.13.2 Start-up

3.13.2.1 Initial operation

The initial operation is performed at a specialist workshop. This also includes mounting of the implement as well as a functional check.

- Obtain instruction from the specialised workshop and ask questions if necessary.
- Read the operating instructions before initial use.
- Check all of the implement functions without a load.
- Check proper functioning of the implement under all operating states.

The adapter is an exchangeable attachment for tractors and is ready for operation after being installed on the Euro change frame and when the implement locking mechanism is closed.

3.13.2.2 Mounting the implement

The adapter is designed to be mounted on a Euro change frame.

- In doing so, observe the description and warnings for mounting implements and operation of the implement locking mechanism in the front loader operating instructions.
- Only couple and uncouple the adapter when it is horizontal.

Coupling the front loader with the adapter onto the Tenias implement:

- ➔ The adapter is mounted on the change frame of the front loader.
 - ➔ The implement is parked on level and solid ground.
- (1) Remove the cotter pin and pull the locking lever to the rear.
 - (2) Pick up the Tenias implement at the centre by the catch hook.
 - (3) Tilt the implement until it is completely resting on the stop of the Tenias adapter.
 - (4) Pull the locking lever to the front and secure the locking mechanism with the cotter pin.
- ✓ The front loader is coupled to the Tenias implement.

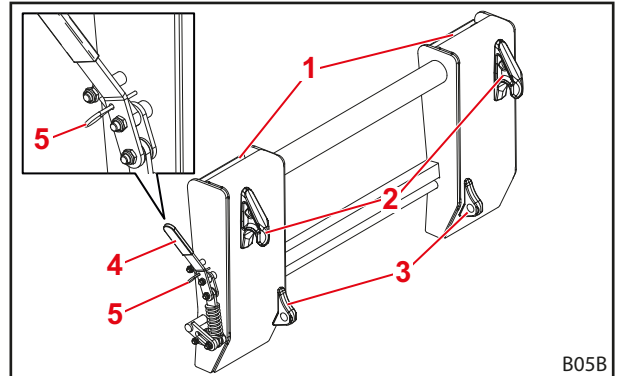

Fig. 93 Coupling the Tenias adapter

Legend

- 1 Tenias catch hook mounts
- 2 Support hooks for change frame
- 3 Support lugs for pins of the change frame
- 4 Locking lever
- 5 Spring cotter pin

3.14 MX implement adapter

3.14.1 Structure and description

The adapter consists of the following components:

- 1 frame
- 1 mechanical locking mechanism
- 1 trigger

The frame is equipped with 2 support hooks and 2 support lugs for the Euro change frame as well as with mountings for an MX implement.

The adapter has a locking mechanism, which triggers the mechanical locking mechanism of the adapter when the change frame is tilted. The locking mechanism is actuated by the trigger. When the adapter is unhooked, the trigger automatically moves to the parking position.

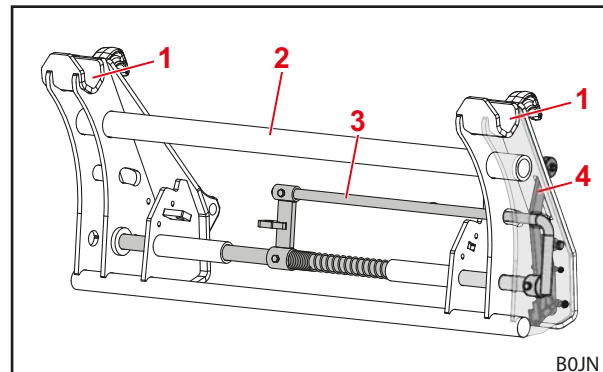

Fig. 94 Structure of the MX implement adapter – Front view

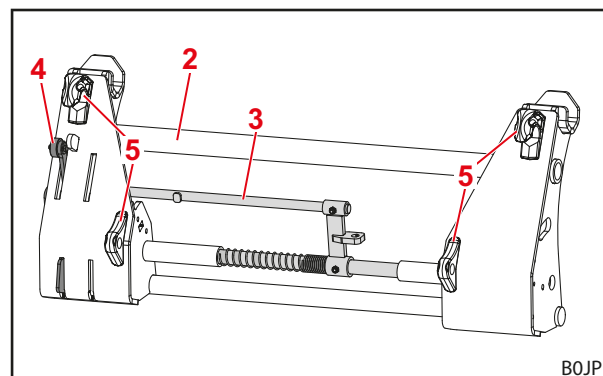

Fig. 95 Structure of the MX implement adapter – Rear view

Legend

- 1 Mountings for MX implement
- 2 Beam
- 3 Mechanical locking mechanism
- 4 Trigger (in parking position)
- 5 Mounts for Euro change frame

3.14.2 Start-up

3.14.2.1 Initial operation

The initial operation is performed at a specialist workshop. This also includes mounting of the implement as well as a functional check.

- Obtain instruction from the specialised workshop and ask questions if necessary.
- Read the operating instructions before initial use.
- Check all of the implement functions without a load.
- Check proper functioning of the implement under all operating states.

When used on ProfiLine FS/FZ 36-20 to 43-34 and FS/FZ 8 to 80 front loaders, the adapter must be converted before initial operation.

- For this, please refer to installation instructions A2270 included with the adapter!

The adapter is an exchangeable attachment for tractors and is ready for operation after being installed on the Euro change frame and when the implement locking mechanism is closed.

3.14.2.2 Mounting the implement

The adapter is designed to be mounted on a Euro change frame.

- In doing so, observe the description and warnings for mounting implements and operation of the implement locking mechanism in the front loader operating instructions.
- Only couple and uncouple the adapter when it is horizontal.

⚠ CAUTION

Risk of crushing due to spring tension!

There is spring tension on the handle of the implement locking mechanism, which closes the locking mechanism when the handle is lifted. Improper use can lead to injury to hands and fingers.

- ▶ Always operate the handle with one hand and grab it in the middle.

Coupling the front loader with the adapter onto the MX implement:

- ➔ The adapter is mounted on the change frame of the front loader.
 - ➔ The implement is parked on level and solid ground.
- (1) Open the implement locking mechanism.
 - Lift the handle and pull out.
 - Move the handle downwards until the nose hooks onto the change frame.
 - (2) Pick up the MX implement at the centre by the mountings.
 - (3) Tilt the implement until it is completely resting on the stop of the adapter.

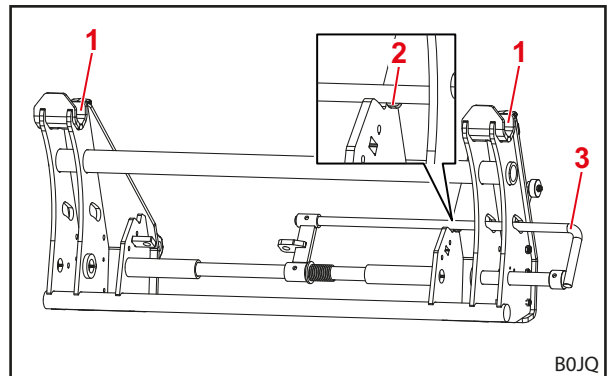

Fig. 96 Attachment position

Legend

- 1 Mountings for MX implement
- 2 Nose
- 3 Handle

i To do this, the front loader may not be lifted to a height of more than 1.5 m.

- ✓ The implement locking mechanism closes automatically.

Check the implement locking mechanism:

- Check that the tip of the arrow on the sticker is aligned directly at the bushing.

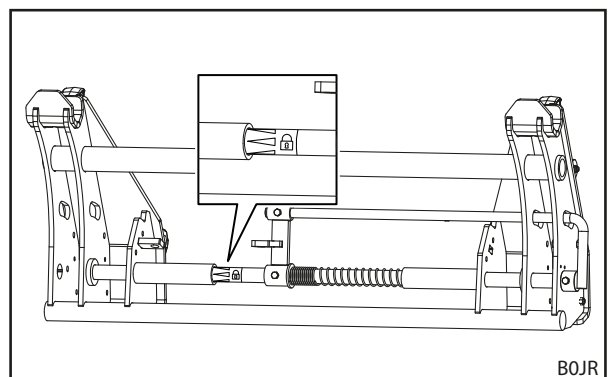

Fig. 97 Using the sticker to check the implement locking mechanism

- Check that both the locking pins engage correctly in the eyelets of the implement.

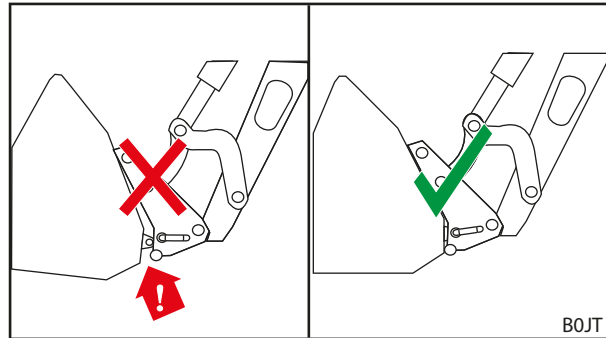

Fig. 98 Checking the position of the locking pins

- Press the implement with the tip on the ground.
- ✓ When locked correctly, the implement remains on the adapter.
- ✓ The implement locking mechanism is checked.
- ✓ The front loader is coupled to the MX implement.

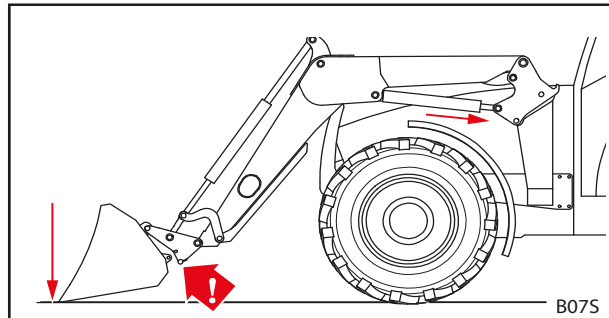

Fig. 99 Pressing the implement onto the ground

3.14.3 Putting down the implement

- see 6.1 *Temporary decommissioning*

When the stability of the adapter/implement unit can be ensured, the adapter is put down together with the implement and remains on the implement. When the stability of the adapter/implement unit cannot be ensured, the adapter and the implement must be put down separately and removed.

4 Troubleshooting

WARNING

Mortal danger and material damage due to lack of safety!

Improperly performed troubleshooting and repair work can impair the safety of the implement.

- ▶ Necessary repair work should only be performed by an authorised specialised workshop.

Faults on the implement are frequently caused by factors that are not a result of a malfunction of the implement or front loader.

In case of faults, first check:

- Is there enough oil in the hydraulic tank of the tractor?
- Has the correct oil been used?
Only use oil types specified in the tractor operating instructions. The wrong oil can cause foam to build up and leaks.
- Is the hydraulic oil clean and free of moisture?
You may need to change the oil and filter.
Install an additional filter in the hydraulic system if necessary.
- Are the hoses and connections mounted correctly?
The connections must be locked in place.
- Are the hoses and connectors undamaged, not clamped or twisted?
- Have the cylinders of the front loader been moved several times into their end positions to remove the air from the lines and the cylinders?
- Have you taken the low outside temperatures into consideration?
Is the oil at operating temperature already?

If these points do not resolve the problem, the following table will help to localize and correct the fault.



Incorrect repairs can lead to safety risks. That is why the repair work must only be carried out by suitably qualified personnel!

STOLL recommends that the repair work be performed at a specialised workshop.

Description of the fault	Cause	Rectifying the fault
Front loader and/or implements work in the wrong direction to the operating lever.	Hydraulic connection is not connected properly.	Check the hydraulic connections, correct if necessary.
	Bowden cables are mounted incorrectly.	Check the connection of the Bowden cables and adjust if necessary.
	Operating lever not aligned correctly.	Check the installation position, and change the connection of the Bowden cables if necessary.

Description of the fault	Cause	Rectifying the fault
The front loader, implement and implement with hydraulic function, such as a top loading grip, move too slowly or not at all.	Not enough oil in the hydraulic system.	Check oil level and refill if necessary.
	Hydraulic couplings are not connected correctly.	Check the connections.
	Tractor pump is worn.	Check the tractor pump, replace if necessary.
	Insufficient oil flow.	Check the tractor hydraulic system.
	Engine speed too low.	Increase engine speed.
	Hydraulic fluid too cold.	Warm up the hydraulic system to operating temperature.
	Too big load in the implement.	Reduce load.
	Hydraulic coupling defective.	Check couplings, replace if necessary.
	Internal leaking in the hydraulic cylinder.	Check the cylinders, repair or replace defective cylinders.
	Pressure relief valve is set incorrectly.	Check the setting of the pressure relief valve.
	Internal leakage in the control block.	Check the control block, replace if necessary.
	Operating lever not adjusted correctly.	Correct the settings of the operating lever.
	The top loading grip valve does not switch.	Check the magnet and shutters, replace if necessary.
Insufficient lifting and tear-out force.	Insufficient oil pressure.	Check the tractor hydraulic system.
	Internal leaking in the hydraulic cylinder.	Check the cylinders, repair or replace defective cylinders.
	Too big load in the implement.	Reduce load.
	The primary or secondary pressure relief valve is incorrectly set or defective.	Check the settings of the pressure relief valve and replace if necessary.
	Internal leakage in the control block.	Check the control block, replace if necessary.
Air in the hydraulic fluid (recognizable by the foamy hydraulic fluid).	The hydraulic pump sucks in air.	Check the lines between the hydraulic pump and tank for loose or defective connections.
	The hydraulic filter is dirty.	Check the hydraulic filter, replace if necessary.
	Low oil quantity in the tank.	Check the oil level, refill if necessary.
	Mixed oil types.	Only use recommended oils.
	Discharging of returning oil.	Connection for returning oil according to the specifications.
Leakage on the hydraulic couplings of the front loader or the 3rd or 4th control circuit.	Leaks caused by infiltrated dirt.	Clean the coupling, replace if necessary. If the front loader or the 3rd or 4th control circuits are not used, seal the hydraulic couplings with the protective caps, or close the cover of the Hydro-Fix.
	Couplings are worn or damaged.	Replace the couplings.
Front loader, implement and implement with hydraulic function is blocked during lifting or lowering movement.	Coupling not completely closed.	Check the hydraulic coupling.
	The coupling is defective.	Replace the defective coupling halves.
	Hydro-Fix, multi-coupler and Implement-Fix not fully closed.	Check the locking lever for deformation. Check the couplings for firm seating, fasten if necessary.
The front loader rocks when lowering the load.	Lowering speed too high.	Reduce the lowering speed.
Unstable implement on FS rapid emptying front loaders (implement tilts away backwards).	Rapid emptying activated without dumping. This causes a vacuum in the hydraulic system.	Only activate the rapid emptying during the dumping process. Increase the engine speed in order to deliver enough oil.

Description of the fault	Cause	Rectifying the fault
The implement cylinder are extended, but are not retracted again.	Piston seal in the implement cylinder is defective, so that the surface of the piston and the ring are stuck together.	Check each cylinder separately for leaks and if necessary replace any defective cylinders.
	Seat valve does not return to starting position after turning on the rapid emptying.	Remove seat valve and check for debris, if necessary, replace.
	Insufficient oil flow.	Check the tractor hydraulic system.
	The double pressure relief valve of the front loader control block does not close.	Clean the double pressure relief valve and replace if necessary.
The front loader is raised when scooping from a lowered position.	Oil shortage on the piston rod side of the lifting arm cylinder.	Increase the engine speed when lowering.
		Lower without float position.
The front loader is raised when scooping from a lowered position, and when subsequently dumping, the front loader is lowered very fast.	Oil shortage on the piston crown side of the lifting arm cylinder.	After the previous error, only actuate the <i>lifting</i> function until the front loader is raised and the implement can be carried in a parallel position.

5 Servicing

WARNING

Serious risk of injury due to uncontrolled lowering of the front loader!

During service and repair work, a raised front loader can be lowered unexpectedly and crush and injure nearby persons.

- ▶ Only perform maintenance work when the front loader is completely lowered.

WARNING

Risk of injury due to hydraulic fluids under high pressure!

Even when the tractor is switched off or the front loader has been removed, the hydraulic system can still be under pressure. If the service work is not carried out correctly, oil can spurt out at high pressure and cause serious injury to persons standing nearby.

- ▶ Before opening the couplings or dismantling hydraulic components, depressurize the hydraulic system.
- ▶ Always used suitable auxiliary materials when searching for leaks.
- ▶ Never search for leaks using your fingers.

CAUTION

Risk of burns by hot machine parts!

Hydraulic components as well as other parts of the front loader and tractor can get very hot during operation. This can cause burns to the skin when performing maintenance work.

- ▶ Allow the machine and components to cool down to under 55 °C before performing maintenance work.

Repairs help to maintain proper functioning of the implement and prevent premature wear. A distinction is made between the following measures:

- Cleaning and care
- Service
- Repairs

5.1 Cleaning and care

NOTICE

Possible material damage due to unsuitable cleaning agents!

Unsuitable cleaning agents can damage surfaces and safety devices as well as destroy gaskets.

▶ Only use cleaning agents that are compatible with the machine surfaces and seal materials.

- Clean the implement with water and a mild cleaning agent.
- Lubricated surfaces of the implement must be re-greased after cleaning.

5.1.1 Lubrication points

Large bale fork

Number of lubrication points: 4

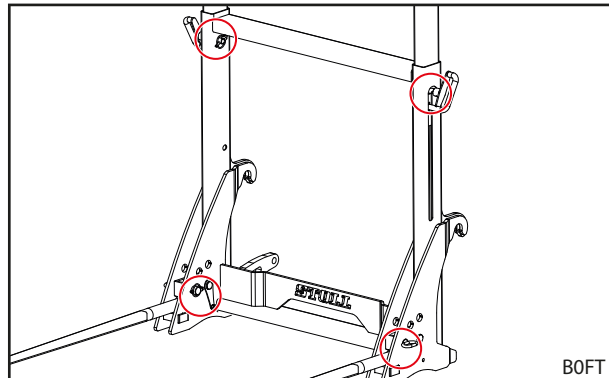

Fig. 100 Large bale fork lubrication points

Large bale fork HS with foldable tines

Number of lubrication points: 2

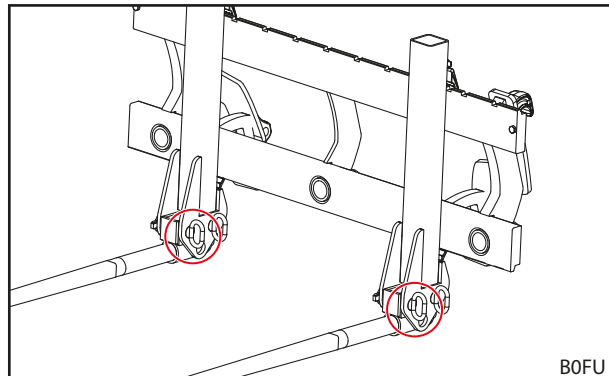

Fig. 101 Lubrication points on the large bale fork HS with foldable tines

Tenias adapter

Number of lubrication points: 5

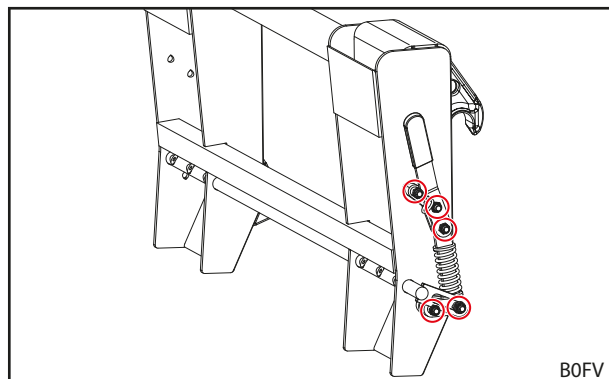

Fig. 102 Tenias adapter lubrication points

5.1.2 Lubrication schedule

Lubrication point	Interval (operating hours)	Lubricant
Bearing positions	10 h	Multipurpose grease DIN 51502 K2K, ISO 6743 ISO-L-XCCEA2, or comparable product



Shorten the lubrication intervals if there is strong dirt contamination.

5.2 Service

WARNING

Lethal danger and material damage due to lack of service!

Service tasks deferred or carried out incorrectly impair the safety of the front loader.

- ▶ Only have service carried out by authorised personnel.
- ▶ Only have visible defects repaired by trained qualified personnel.
- ▶ Observe additional documentation, e.g. for implements, for other service tasks.

To ensure proper operating condition of the implement, the defined service tasks must be performed at the specified intervals by qualified personnel.

- Have service tasks performed regularly according to the service intervals described in the following.

5.2.1 Service schedule

The specified service intervals are guidelines.

- Adjust the intervals according to the operating conditions.
- Consult with a workshop for any questions.

Maintenance position	Job	Interval (operating hours)
Check the screw connections	Check, tighten if necessary	100 h
Bearing positions	Visual inspection	10 h
	Lubrication (see 5.1.2 Lubrication schedule)	10 h

Load hook

Maintenance position	Job	Interval (operating hours)
Hook	Check for wear (see 5.2.2 Service instructions for load hook)	10 h

5.2.2 Service instructions for load hook

WARNING

Risk of serious injury due to the load breaking off!

When the load hook is strongly worn, the load can break off of the load hook. Bystanders can be seriously injured and the load can be damaged.

- ▶ Check the load hooks regularly for wear.
- ▶ Only pick up the load with load hooks that are not worn or damaged.
- ▶ Worn or damaged load hooks must be replaced by an authorised specialist workshop.

To check the wear on the load hook, observe the following:

- The wear depth on the deepest point of the bottom of the hook may not be greater than 5 % of the nominal dimension of the hook height.
- The widening of the hook mouth must not exceed 10 %.
- The hook mouth must not be twisted.
- The hook safety lock must be checked for proper function.

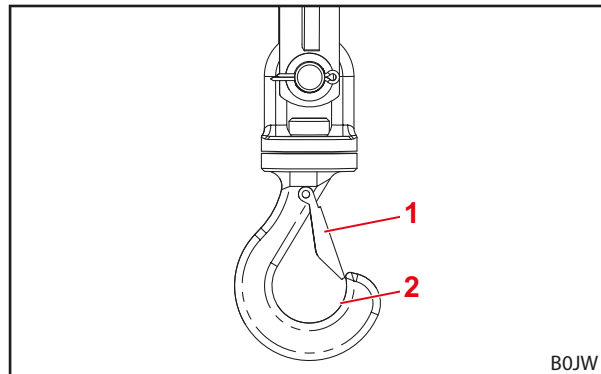

Fig. 103 Load hook

Legend

- 1 Hook safety lock
- 2 Hook mouth

5.3 Repairs

WARNING

Mortal danger and material damage caused by repair work carried out incorrectly!

Repair work carried out incorrectly can impair the safety of the front loader and can lead to serious accidents and injuries.

- ▶ Repair work should only be performed by an authorised specialised workshop.

Repairs involve the replacement and repair of components. This is only necessary if components are damaged after wear or due to external circumstances.

The specialised workshop must:

- Perform all required repair work professionally and complying with the applicable regulations and according to the rules of engineering.
- Worn or damaged parts should never be provisionally repaired.
- Only use original or approved spare parts for repairs (see 7.1 Spare parts).
- Replace the gaskets.

6 Decommissioning

6.1 Temporary decommissioning

⚠ WARNING

Risk of injury due to implement tipping over!

If the implement is not in the required position to be safely put down, the implement can tip over. This can cause injuries to persons.

- ▶ Observe the instructions for putting down the implement in the respective chapter for the implement.
- ▶ Ensure that the implement is stable.

Putting down the implement:

- (1) Lower the front loader close to the ground and position the implement horizontally on the ground or place on a secure rack.



Do not completely lower the front loader onto the ground.

- (2) Switch off the tractor.
 - Apply the parking brake.
 - Stop the engine.
 - (3) Open the implement locking mechanism (see front loader operating instructions).
 - (4) Switch on the tractor.
 - (5) Lower the implement to the ground.
 - (6) Unhook the change frame from the implement hooks.
 - Use the *dumping* function until the upper cross bar is positioned under the implement hook.
 - (7) Slowly drive the tractor away in reverse.
 - (8) Check that the implement is in a stable position.
 - (9) If applicable, cover the implement with a protective tarp.
- ✓ The implement is put down.

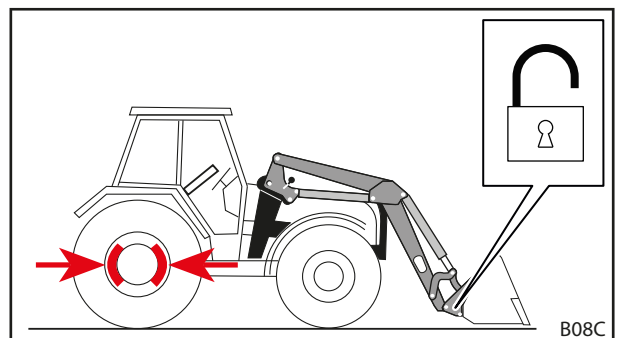

Fig. 104 Opening the implement locking mechanism

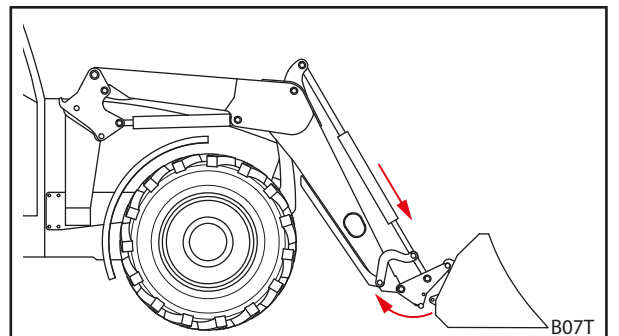

Fig. 105 Unhooking the change frame

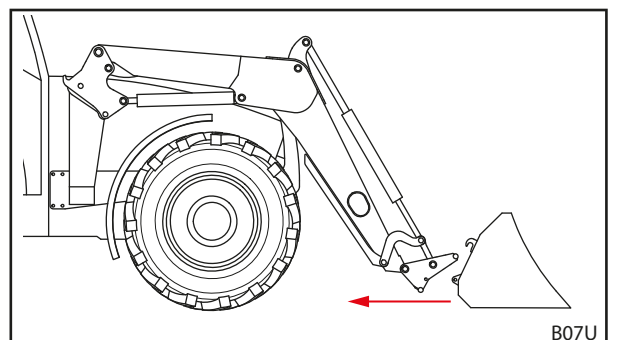

Fig. 106 Driving away

6.2 Recommissioning

Recommissioning the implement:

- (1) If necessary, take the protective tarpaulin off of the implement.
- (2) Clean the implement if necessary.
- (3) Have maintenance performed on the implement if necessary (see 5.2.1 Service schedule).
- (4) Perform a "Check before each start-up" (see chapter for the respective implement).
- (5) Check all of the implement functions.
 - ✓ The implement is ready for operation again.

6.3 Final decommissioning and disposal

NOTICE

Environmental damage due to improper disposal!

The implements consist essentially of components made of steel and hydraulic components, which may contain, among other things, rubber and plastics which must be disposed of separately. Improper disposal can harm the environment.

- ▶ Observe the national and local regulations and environmental legislation for the disposal.
- ▶ Hand the implement over to the dealer or a specialised company for disposal.

The implement does not have a limit on its service life. In case of disposal, the implements must be decommissioned and disposed of correctly.

- Also observe the safety instructions for service and maintenance.

7 Spare parts and customer service

7.1 Spare parts

⚠ WARNING

Risk of injury and material damage due to using the wrong spare parts!

The use of non-approved spare parts can impair the safety of the implement and results in expiry of the operating permit.

- ▶ Only use original spare parts or those approved by STOLL.

Original spare parts and fitting accessories are listed in separate spare part lists.

- Download spare part lists at www.stoll-germany.com.

Order information for safety stickers

Locking grate HS:

Order no.	Designation	Stickers included
3671510	"Transport frame" sticker	1 sticker at Pos. no. 1

Bigbag lifter:

Order no.	Designation	Stickers included
3629340	"Safety angle" sticker	1 sticker at Pos. no. 1

Load hook:

Order no.	Designation	Stickers included
3547030	"Max. 2000 kg" sticker	1 sticker at Pos. no. 1

MX implement adapter:

Order no.	Designation	Stickers included
3431550	Label sheet "Technology yellow"	1 sticker at Pos. no. 1

7.2 Customer service

For further questions regarding your front loader, please contact your dealer.

8 Technical specifications

8.1 Dimensions and weights

8.1.1 Pallet forks

8.1.1.1 Pallet fork HD

Pallet fork HD (without tine sockets)

Id. no.	Tine length [mm]	Permissible payload [kg]	Weight [kg]
3583680	1200	2500	199
3583700	1200	1600	169
3583710	1000	1600	161

Pallet fork HD (with tine sockets)

Id. no.	Width [mm]	Tine length [mm]	Permissible payload [kg]	Weight [kg]
3646850	1250	1200	2500	196
3654360	1250	1200	1600	166
3654370	1250	1000	1600	158

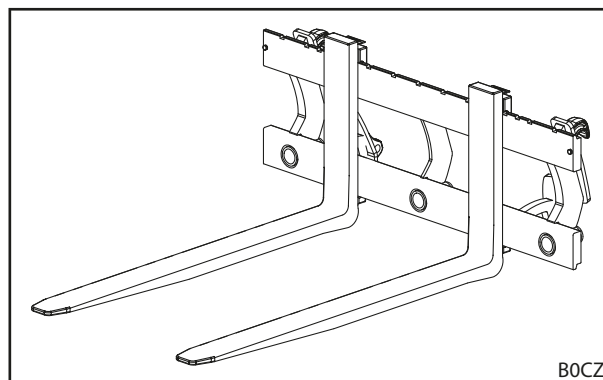

Fig. 107 Pallet fork HD with tine sockets

Pallet tines

Id. no.	Tine length [mm]	Permissible payload [kg]	Weight [kg]
3570710	1000	800	32
3570720	1200	800	36
3570730	1200	1250	51

Pallet fork HD 3.5 t (for FZ 100, 80.1, 60.1 and 60 front loaders)

Id. no.	Tine length [mm]	Permissible payload [kg]	Weight [kg]
3579550	1200	3500	322

8.1.1.2 Pallet fork HS 1500

Id. no.	Tine length [mm]	Permissible payload [kg]	Weight [kg]
3430830	1000	1600	179
3434900	1200	1600	187

Pallet tines

Id. no.	Tine length [mm]	Permissible payload [kg]	Weight [kg]
3570710	1000	800	32
3570720	1200	800	36

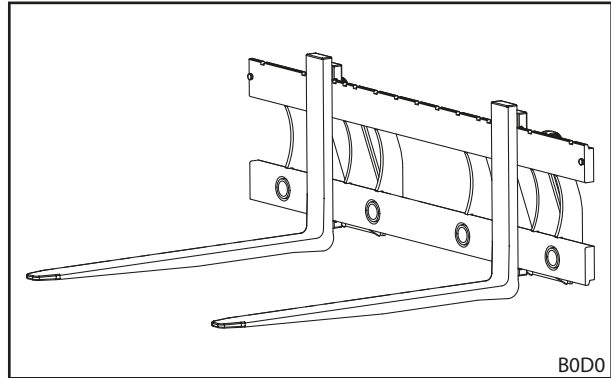

Fig. 108 Pallet fork HS 1500

8.1.1.3 Pallet fork Global

Id. no.	Tine length [mm]	Permissible payload [kg]	Weight [kg]
3567980	1000	1000	113

Pallet tines

Id. no.	Tine length [mm]	Permissible payload [kg]	Weight [kg]
3570700	1000	500	27

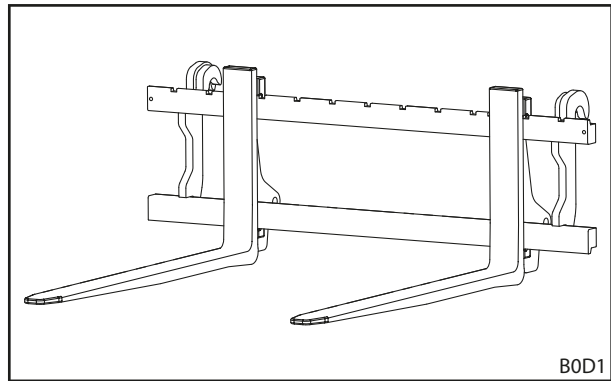

Fig. 109 Pallet fork Global

8.1.2 Bale tubes

Id. no.	Weight [kg]
3405090	36

8.1.3 Large bale fork

Id. no.	Width [mm]	Tine length [mm]	Permissible payload [kg]	Weight [kg]
3611920	1135	1200	1000	147

8.1.4 Large bale fork HS

Id. no.	Tine length [mm]	Permissible payload [kg]	Weight [kg]
3684190	1200	2000	137
3684200	1200 (foldable tines)	2000	143

Bale tine HS

Id. no.	Tine length [mm]	Permissible payload [kg]	Weight [kg]
2400050	1200	1000	20
3331520	1200 (foldable)	1000	23

8.1.5 Locking grate HS

Id. no.	Weight [kg]
3570550	23
3553710	27

8.1.6 Bale transport devices

Bale transport device H

Id. no.	Gripping range [mm]	Arm length [mm]	Permissible payload [kg]	Weight [kg]
3380410	820 - 1220 (at 5-cm intervals)	1280	500	105

Bale transport device rear

Id. no.	Gripping range [mm]	Arm length [mm]	Permissible payload [kg]	Weight [kg]
3336750	940 - 1340 (at 5-cm intervals)	1280	500	115

8.1.7 Bale spikes

8.1.7.1 Bale spike H

Id. no.	Width [mm]	Tine length [mm]	Permissible payload [kg]	Weight [kg]
3378240	1000	1x800, 1x1200	1000	90
3411860	1000	2x1200	1000	94
3484720	1000	2x800	1000	86

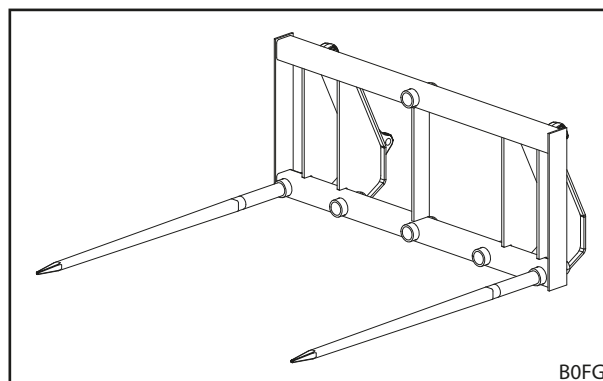

Fig. 110 Bale spike H

Tines

Id. no.	Tine length [mm]	Permissible payload [kg]	Weight [kg]
0476240	800	1000	5
1330130	1200	1000	9

8.1.7.2 Bale spike Global

Id. no.	Width [mm]	Tine length [mm]	Permissible payload [kg]	Weight [kg]
3611810	1275	2x800	700	68
3608420	1275	2x1200	700	76
3550600	1275	2x1100	700	69

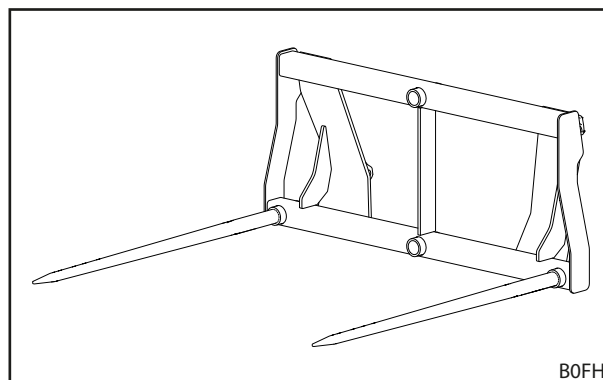

Fig. 111 Bale spike Global

Tines

Id. no.	Tine length [mm]	Permissible payload [kg]	Weight [kg]
0476240	800	500	5
1330130	1200	500	9

8.1.7.3 Bale spike Skid

Id. no.	Width [mm]	Tine length [mm]	Permissible payload [kg]	Weight [kg]
3718550	1271	1x800, 1x1200	700	65

Tines

Id. no.	Tine length [mm]	Permissible payload [kg]	Weight [kg]
0476240	800	500	5
1330130	1200	500	9

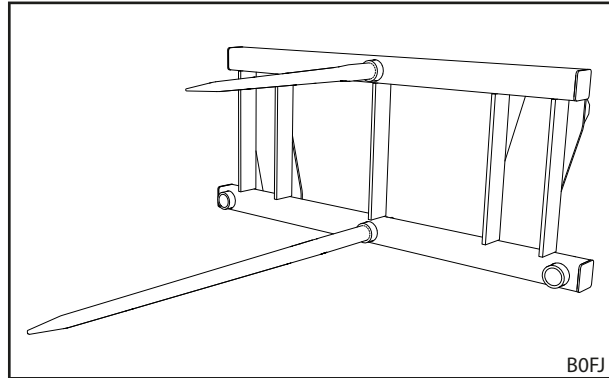

Fig. 112 Bale spike Skid

8.1.8 Manure forks
Manure fork

Id. no.	Width [mm]	Tine length [mm]	Number of tines	Permissible payload [kg]	Weight [kg]
3364760	1250	810	7	730	125
3364690	1500	810	8	880	145
3364520	1750	810	10	1000	165

Manure fork (for FZ 60/60.1/80.1/100 front loaders)

Id. no.	Width [mm]	Tine length [mm]	Number of tines	Permissible payload [kg]	Weight [kg]
3611820	2000	810	11	1130	243
3611830	2000	1100	11	1650	264
3611930	2250	1100	12	1850	288
3660460	2500	1100	14	2100	318

Side tines

Id. no.	Tine length [mm]	Weight [kg]
3534780	500	4

Loading grid

Id. no.	Width [mm]	Weight [kg]
3599680	2000	40

8.1.9 Log fork H

Id. no.	Permissible payload [kg]	Weight [kg]
1317750	1000	150

8.1.10 Bigbag lifter

Id. no.	Width [mm]	Lifting height over implement pivot point [mm]	Permissible payload [kg]	Weight [kg]
3602900	1120	1500	1000	115

8.1.11 Bag-Lift H

Id. no.	Width [mm]	Lifting height over implement pivot point [mm]	Permissible payload [kg]	Weight [kg]
2357100	1380	500	1000	180

8.1.12 Load hook

Id. no.	Width [mm]	Permissible payload [kg]	Weight [kg]
2309670	840	2000	16

8.1.13 Tenias adapter

Id. no.	Width [mm]	Permissible payload [kg]	Weight [kg]
3664360	1420	1000	70

8.1.14 MX implement adapter

Id. no.	Width [mm]	Permissible payload [kg]	Weight [kg]
3733790	1188	4200	78

8.2 Noise emissions

The emission sound pressure level is less than 70 dB(A) (depending on the tractor).

8.3 Tightening torques for screws

Tightening torque for screws						
Thread	Strength category					
	8.8		10.9		12.9	
	Nm	lb-ft	Nm	lb-ft	Nm	lb-ft
M4	3	2	4.5	3	5	4
M6	11	8	15	11	17	13
M8	27	20	36	27	42	31
M8x1	29	21	38	28	45	33
M10	54	40	71	52	83	61
M10x1.25	57	42	75	55	87	64
M12	93	69	123	91	144	106
M12x1.5	97	72	128	94	150	111
M12x1.25	101	74	133	98	155	114
M14	148	109	195	144	229	169
M14x1.5	159	117	209	154	244	180
M16	230	170	302	223	354	261
M16x1.5	244	180	320	236	374	276
M18	329	243	421	311	492	363
M18x2	348	257	443	327	519	383
M18x1.5	368	271	465	343	544	401
M20	464	342	592	437	692	510
M20x2	488	360	619	457	724	534
M20x1.5	511	377	646	476	756	558
M22	634	468	807	595	945	697
M22x2	663	489	840	620	984	726
M22x1.5	692	510	873	644	1022	754
M24	798	589	1017	750	1190	878
M24x2	865	638	1095	808	1282	946
M27	1176	867	1496	1103	1750	1291
M27x2	1262	931	1594	1176	1866	1376
M30	1597	1178	2033	1499	2380	1755
M30x2	1756	1295	2216	1634	2594	1913
5/8" UNC (normal)	230	170	302	223		
5/8" UNF (fine)	244	180	320	236		
3/4" UNC (normal)	464	342	592	437		
3/4" UNF (fine)	511	377	646	476		



Make sure that the threads are clean! The specified tightening torques are valid for screws and threads that are clean, dry and free of grease.

9 Declaration of Conformity

(in accordance with EC Directive 2006/42/EC, Appendix II 1.A)

The
 Wilhelm STOLL Maschinenfabrik GmbH
 Bahnhofstrasse 21
 D-38268 Lengede, Germany

hereby declares that the machine in its state on delivery complies with the directives and harmonised standards listed in the following, and will be made available on the market:

Designation:	Implement
Type:	Pallet fork HD, ID numbers 3583710, 3583700, 3583680, 3654370, 3654360, 3646850, 3579550 Pallet fork HS 1500, ID numbers 3430830, 3434900 Pallet fork Global, ID number 3567980 Large bale fork, ID number 3611920 Large bale fork HS, ID numbers 3684190, 3684200 Bale transport device rear, ID number 3336750 Bale transport device H, ID number 3380410 Bale spike H, ID numbers 3378240, 3411860, 3484720 Bale spike Global, ID numbers 3550600, 3608420, 3611810 Bale spike Skid, ID number 3718550 Bigbag lifter, ID number 3602900 Bag-Lift H, ID number 2357100 Manure forks, ID numbers 3364760, 3364690, 3364520, 3611820, 3611830, 3611930, 3660460 Log fork H, ID number 1317750 Load hook, ID number 2309670 Tenias adapter, ID number 3664360 MX implement adapter, ID number 3733790
Machine no.:	5400000 to 5999999
With the intended use/ function:	As a mounted implement, the implement is "interchangeable equipment" as defined by the Machinery Directive 2006/42/EC. The implement is mounted on front loaders on agricultural and forestry tractors using a change frame, and serves to perform processes and tasks in the agricultural and forestry sector. Further information on the intended use with the operating conditions, the description, the function and other technical data for the implement can be found in the operating instructions.

The machine complies with all relevant and applicable provisions of the

- Council Directive 2006/42/EC on machinery,
- Directive 2014/30/EU of the European Parliament and the Council for Electromagnetic Compatibility (EMC).

The technical documentation was produced according to Annexe VII A of Directive 2006/42/EC, and is the responsibility of the head of the Engineering Center at Wilhelm STOLL Maschinenfabrik GmbH, Bahnhofstrasse 21, D-38268 Lengede.

The design and manufacturing of the implement observed the following harmonised standards that are also published in the EU official gazette:

Harmonised standards	Date	Title of the standard
DIN EN ISO 4254-1	2016-09	Agricultural machinery - Safety - Part 1: General requirements
DIN EN 12525	2011-02	Agricultural machinery - Front loader safety
DIN EN ISO 12100	2011-03	Safety of machinery - Basic terms, General principles for design for the safety of machinery - General principles for design - Risk assessment and risk reduction
DIN EN ISO 13857	2020-04	Safety of machinery - Safety distances to prevent hazard zones being reached by upper and lower limbs
EN ISO 14982	2009-12	Agricultural and forestry machines - Electromagnetic compatibility - Test methods and acceptance criteria

Lengede, 01.12.2022



Marc Bockelmann
Managing Director



Ulrich Flötzinger
Head of the Engineering Center

Index

B

Bag-Lift H 12, 60, 82
 Bale spike Global 12, 46
 Bale spike H. 12, 46
 Bale transport device H 12, 41
 Bale transport device rear 41
 bale transport device rear 12
 Bale transport device H 80
 Bale transport device rear 80
 Bale tubes. 11, 24, 29, 79
 Behaviour in case of emergency 23
 Bigbag lifter.. 12, 20, 56, 81

C

Check before each start-up 26, 31
 Cleaning.. 73

D

Danger areas. 19
 Danger due to emissions. 15
 Dangers during installation for start-up . 15
 Dangers during loading work 16
 Dangers during maintenance 18
 Dangers during packaging and
 transport.. 15
 Dangers when operating the front
 loader. 17
 Dangers when picking up and putting down
 implements 16
 Disposal.. 77
 Documentation overview 6

E

EC conformity 10
 Electrical dangers.. 15

F

Faults. 70

H

Hydraulic dangers.. 13, 18

I

Initial operation 25, 31, 35, 42, 47, 50, 53, 57,
 60, 63, 65, 67

L

Large bale fork.. 11, 30, 73, 79
 Large bale fork HS. 11, 34, 73
 Load hook. 12, 21, 62, 82
 Locking grate HS . . . 11, 20, 24, 34, 39, 80
 Log fork H. 12, 53, 81
 Lubrication schedule 74

M

Manure fork. 12, 49, 81
 Mechanical dangers 14
 MX implement adapter. 12, 21, 67, 82

O

Operational limits 13

P

Pallet fork Global 11, 24, 79
 Pallet fork HD 11, 24, 78
 Pallet fork HS 1500 11, 24, 79
 Protective and safety equipment. 19
 Putting down the implement. 76

R

rating plate 7
 Recommissioning.. 77
 Repairs 72, 75

S

Safety and warning notifications 10
 Safety stickers.. 20
 Service intervals. 74
 Spare parts.. 77

T

Tenias adapter.. 12, 65, 73, 82
 Tightening torques for screws 83

Address of the dealer

Stick or write down the serial number here



Wilhelm STOLL Maschinenfabrik GmbH

PO box 1181, 38266 Lengede

Bahnhofstr. 21, 38268 Lengede

Phone: +49 (0) 53 44/20 222

Fax: +49 (0) 53 44/20 182

E-mail: info@stoll-germany.com

STOLL on the Internet:

www.stoll-germany.com

www.facebook.com/STOLLFrontloader

www.youtube.com/STOLLFrontloader