

**STOLL**



**A NEW ERA  
OF FRONT  
LOADERS.**

**ProfiLine  
ISOBUSConnected**

# ISOBUS FUNCTIONS.

- Ultimate Performance
- Premium Comfort
- Faster connectivity

The unique STOLL ProfiLine ISOBUSConnected features take front loader and tractor work to a new level of comfort, user-friendliness and precision.



## BENEFITS

The new STOLL ProfiLine ISOBUSConnected brings the full integration of the front loader into the tractor system. The new system settings, new level of comfort and higher safety standards.

The ISOBUS standard unifies the communication between the tractor and the new Stoll's front loader. Thanks to it ISOBUSConnected front loader can be fully integrated into the tractor.

With the STOLL ProfiLine ISOBUSConnected, the front loader can be connected to the tractor control unit and operated by the tractor joystick and terminal

In addition to the electro-hydraulic parallel levelling on the FS model, the new STOLL ProfiLine ISOBUSConnected system also offers professional functions that turn the tractor with the Stoll front loader into a true professional machine.

## 12 UNIQUE FUNCTIONS OF PROFILINE ISOBUSCONNECTED



**pLimit**

Pressure Regulation

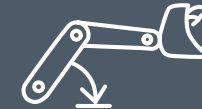

Load Independent Lowering Speed

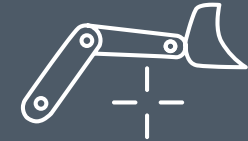

Teach In

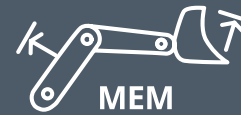

**MEM**

Return To Position



Adjustable Response Behaviour

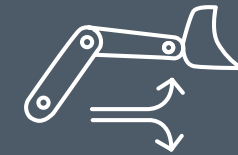

Electric Flow Sharing

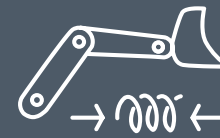

End Position Damping

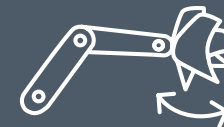

Bucket Shake

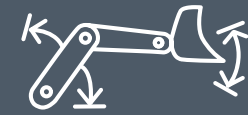

Working Window

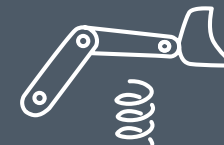

Vibration Damping



Weighing

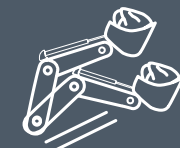

Electric Hydraulic Parallel Leveling

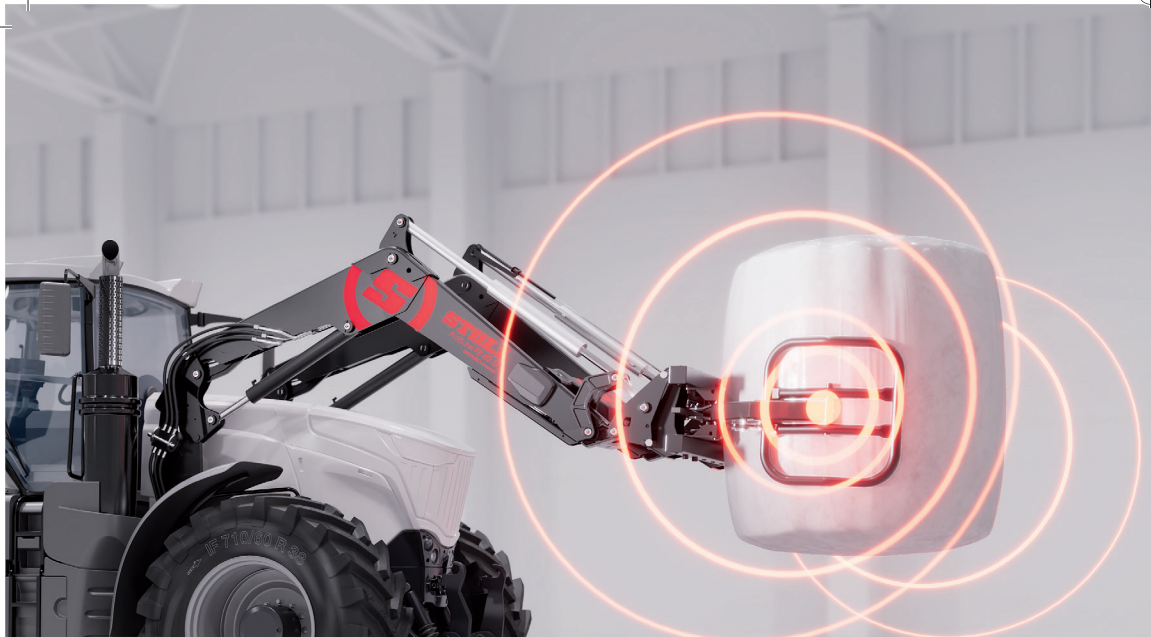

## FUNCTION 1

# PRESSURE REGULATION



Overload protection implement  
Pressure regulation  
Machine overload protection

### Pressure limitation on the bale grab application

This function enables the convenient and protective use of a bale grab and protects the plastic wrapping from damage, as the clamping force can be individually adjusted by pressure limitation. The control unit regulates the pressure in the 3rd function via the valve to a previously defined value.

### Pressure relief function, e.g. for a motorised drive

This function prevents overloading, e.g. due to jamming of a hydraulic actuator. If the pressure exceeds a previously defined value, the valve is regulated back so that the defined pressure range is maintained.

## FUNCTION 2

# LOAD INDEPENDENT LOWERING SPEED

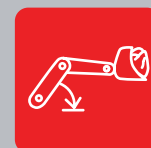

Controlled lowering  
Load independent  
Maximum comfort

### Load independent lowering

The same lowering and lifting speed regardless of the load.

The lowering speed is reduced by throttling at the return side. Due to the rigid design, the return throttling is too high without load and unnecessary power loss occurs; with load it is too low and the lowering speed is too high. The automatic adjustment of the return oil adapts to the weight of the implement and the speed remains stable regardless of the load. The speed corresponds to the preselection by the joystick deflection. (Up-down same speed, on/off function).



### FUNCTION 3

## TEACH IN



Defined movement sequence  
Simple operation  
More power

#### Programmable movement sequences

When the teach-in function is switched on, a movement sequence is saved. A complete movement cycle can be saved by running through it. When activated, the liftarm and the tool are controlled accordingly. This movement cycle for the liftarm and implement is repeated accordingly when activated.

Settings: Define, save and call up the movement cycle..

### FUNCTION 4

## RETURN TO POSITION



Faster work  
Precise, recurring position  
Stress-free working

#### Return to Position

The operator defines a position to be approached. The position is approached by moving the boom and implement. The set position is saved and is approached automatically. To simplify recurring sequences, two positions, an upper and a lower position can be approached with a simple signal (pressing a button and moving the joystick).

Readjustment using the joystick is not necessary. In independent mode, the saved position of the liftarm and implement can be approached separately. In linked mode - the saved position of both the liftarm and implement will be approached.

The return to position is an on/off function.



## FUNCTION 5

# ADJUSTABLE RESPONSE BEHAVIOUR



Load-independent  
Adjustable response behaviour of the front loader  
High power

### Adjustable Response Behaviour

The aim is to increase comfort and enable material-friendly working. In order to meet the needs of the operator, the response behaviour can be defined independently and flexibly. The response behaviour defines the time from the joystick deflection to the full deflection of the control spool.

The start time and stop time are different;  
Load A and B start time, load A and B stop time. The times can also be defined as a function of the load.  
The response behaviour is thus optimally adapted to the current work situation.

Settings: Response behaviour, without weight dependency (four parameters).

## FUNCTION 6

# ELECTRIC FLOW SHARING



Priority control  
Adjustable  
Smooth switching

### Electronic volume splitting

The maximum possible pump volume is determined by the speed and displacement of the pump. If the desired volume flow is higher via the control of the valve segments, the volume of the controlled consumers is reduced proportionally so that the inflow volume and the pump volume are equal.

### Priority functions possible

It can be defined that the volume flow is not reduced for defined functions.  
A disproportionate volume flow reduction is also possible (on/off function).



## FUNCTION 7

# END POSITION DAMPING



Load dependent  
Protection of the machine  
Improved comfort

### End Position Damping

The aim of end position cushioning is to avoid a hard impact in the end position of the cylinder. A reference delay is calculated depending on the speed of the consumer. With this function, the approach to the end position is gentle yet dynamic.

Sharp braking when reaching the end positions can be prevented. The hard impact on the driver and the load on the material is avoided by calculating the kinetic energy and determining the required deceleration distance.

The protection of the material and the improved driving comfort of this on/off function is adjustable and therefore always guaranteed.

## FUNCTION 8

# BUCKET SHAKE

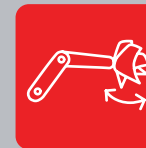

Adjustable frequency  
Clean emptying  
Work efficiency

### Complete emptying

If material gets stuck in the bucket, the shaking function can be activated. The bucket is moved back and forth quickly and the material falls out.

The duration can be adjusted. The amplitude is determined by the deflection of the joystick. The vibration function can also be provided with a decaying amplitude.

The bucket moves horizontally to a defined position. Then the blade moves up and down with smaller amplitudes.

The setting of the frequency depends on the load of the material properties. The amplitude correlates with the deflection of the joystick of this on/off function.



## FUNCTION 9

# WORKING WINDOW



Operator defined working range  
 Reduced risk of accidents  
 Improved manoeuvrability

### Working area

The aim is to adjust the end strokes electronically in order to avoid collisions or facilitate manoeuvrability. The permissible movement range of the front loader is determined by the electrical upper and lower end stroke.

It is possible to define:

- upper position
- lower position
- both positions together

The possible movement range of the front loader is now limited within the defined range (on/off function).

## FUNCTION 10

# VIBRATION DAMPING



Load independent  
 Adjustable  
 Switchable

### Vibration Damping

Reduces the movement of the vehicle on uneven road surfaces. The implement is used as a mass absorber by means of a switchable accumulator. The switchable accumulator dampens the vibrations of the vehicle body accordingly.

The vibration dampening reduces the movement of the implement, which transmits shocks to the implement due to uneven road surfaces. The implement is isolated from the bodywork by the vibration damping.

The dampening of the system can be adjusted. The amount of oil flow depends on the valve opening and is adjusted via the regulator.



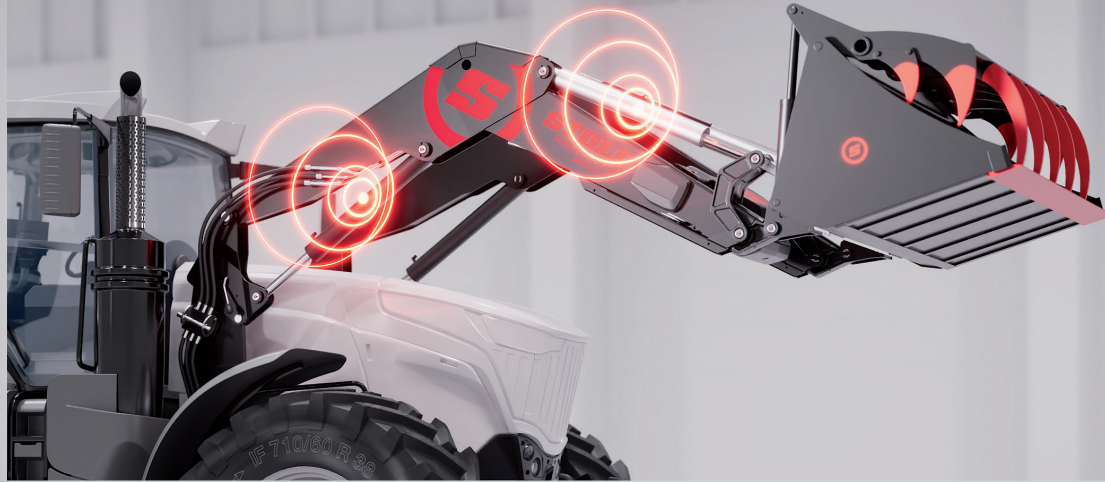

## FUNCTION 11

# WEIGHING



Flexible position for weighing  
Travelling and weighing  
High accuracy

### Weighing

Each implement is calibrated once and the corresponding data is saved. The attached implement can be selected accordingly by the operator. When the operator presses the button and the loader is in the measuring range (weighing range), the weighing process is started and the weight is calculated based on the pressure and geometry data.

The result is shown on the display. The accuracy is  $\pm 1\%$  (of the max. weight). If several weighing processes are carried out, the weighing results can be added together automatically (total weight).

A total weight can be entered, which is automatically subtracted and the required "remaining weight" is automatically calculated and displayed. The loader must be stopped, before the weighing process can be carried out.



## FUNCTION 12

# ELECTRIC HYDRAULIC PARALLEL LEVELING



Fewer mechanical components  
Highest precision  
Rapid dump function for quick emptying

### Electric Hydraulic Parallel Leveling (available only for FS loaders)

With parallel guidance, the implement is automatically held in the defined position when the front loader is moved up and down. The angle to the ground is automatically corrected so that the position of the implement in relation to the ground remains the same.

The movement of the boom cylinder is determined by the deflection of the joystick. The angle of the implement is calculated and adjusted accordingly with very high accuracy when the boom is raised or lowered.

The function can be switched on and off.

# ISOBUSCONNECTED SPECIFICATION.

The new era of front loaders is here. STOLL ProfiLine ISOBUSConnected ensures maximum integration of the loader into your tractor.

## TECHNICAL DATASHEET

PROFILINE NEXT GENERATION ISOBUSCONNECTED				SIZE 2				SIZE 3				SIZE 4				SIZE 5				SIZE 6		
FZ (mechanical self-leveling)				FZ IB+ 39-23	FZ IB+ 39-27	FZ IB+ 39-31		FZ IB+ 41-25	FZ IB+ 41-29	FZ IB+ 41-33		FZ IB+ 43-27	FZ IB+ 43-30	FZ IB+ 43-34		FZ IB+ 46-26	FZ IB+ 46-29	FZ IB+ 46-33		FZ IB+ 48-33	FZ IB+ 48-37	FZ IB+ 48-42
FS (hydraulic self-leveling)							FS IB+ 39-35				FS IB+ 41-37				FS IB+ 43-38				FS IB+ 46-37			
Suitable for tractors with kW/hp			kW hp	45-95 60-130	60-95 80-130	65-95 90-130		60-120 80-160	75-120 100-160	80-120 110-160		75-130 100-180	85-130 110-180	95-130 130-180		95-190 130-260	105-190 140-260	120-190 160-260		140-220 190-300	150-220 200-300	155-220 210-300
Lifting force approx. in the implement's pivot point	below	Q1	daN	2300	2670	3070	3490	2510	2880	3280	3710	2660	3060	3420	3830	2580	2940	3320	3720	3320	3730	4150
	above	Q2	daN	1850	2140	2460	2800	2040	2340	2660	3010	2230	2530	2860	3210	2280	2600	2930	3290	2760	3100	3450
Lifting force (blade) approx. 300 mm before the pivot point	below	N1	daN	2300	2670	3070	3000	2510	2880	3280	3210	2660	3060	3420	3360	2580	2940	3320	3290	3320	3730	4150
	above	N2	daN	1850	2140	2460	2510	2040	2340	2660	2700	2230	2530	2860	2900	2280	2600	2930	2990	2760	3100	3450
Lifting force (pallet) approx. 800 mm before the pivot point	below	M1	daN	2300	2670	3070	2430	2510	2880	3280	2620	2660	3060	3420	2785	2580	2940	3320	2750	3320	3730	4150
	above	M2	daN	1850	2140	2460	2130	2040	2340	2660	2320	2230	2530	2860	2500	2280	2600	2930	2600	2760	3100	3450
Breakout force 800 mm before the pivot point	below	R	daN	2910	3550	3550	3080	2900	3540	3850		3540	4580			3840	4560			4140	4900	
800 mm lift height in the implement's pivot		H	mm	3850				4100				4320				4550				4800		
Overloading height (H-210)		L	mm	3640				3890				4110				4340				4590		
Dump height		A	mm	2810				3060				3290				3490				3750		
Dump width		W	mm	700				790				780				800				880		
Digging depth		S	mm	210				210				210				210				210		
Pivot point of lifting arms		B	mm	1800				1945				1945				2045				2180		
Tilt angle	below	X	° degree	44°				44°				44°				44°				45°		
	rescooped	X1	° degree	61°		-		61°		-		61°		-		63°		-		62°		
Dumping angle	above	Z	° degree	57°				57°				56°				58°				58°		
Pump output rate			l/min	75				90				90				100				120		
Lifting cylinder			mm	Ø 65 mm	Ø 70 mm	Ø 75 mm	Ø 80 mm	Ø 70 mm	Ø 75 mm	Ø 80 mm	Ø 85 mm	Ø 75 mm	Ø 80 mm	Ø 85 mm	Ø 90 mm	Ø 75 mm	Ø 80 mm	Ø 85 mm	Ø 90 mm	Ø 85 mm	Ø 90 mm	Ø 95 mm
Stroke time			sec.	3,4	3,9	4,5	5,1	3,3	3,8	4,3	4,8	3,8	4,3	4,8	5,4	3,6	4,3	4,7	5,3	3,8	4,2	4,7
Tilting time, implement			sec.	0,6	0,7	0,7	0,6	0,5	0,6	0,6	0,6	0,6	0,7	0,7	0,7	0,6	0,7	0,7	0,6	0,5	0,6	0,6
Dumping time, implement			sec.	1,3	1,6	1,6	2,2	1,1	1,3	1,4	2,1	1,3	1,7	1,7	2,3	1,3	1,6	1,6	2,1	1,2	1,4	1,4
Weight, lifting arms without implement			kg	604	610	612	575	650	657	665	615	767	770	775	710	852	860	864	790	886	890	898

Values given are average values, depending on tractor type and loader equipment, there may be deviations upwards or downwards.  
The specified lifting forces are only applicable for the specified height of the swing pivot point. B calculated for 195 bar hydraulic pressure.

# SMARTER. FASTER.

## SELF-LEVELING MODELS

FZ



Mechanic self-levelling

FS



Hydraulic self-levelling

## DISPLAY



User-friendly visualized control and setting of front loader parameters via the tractor's integrated display.

This functionality may vary depending on the specific tractor model.

## DIMENSIONS

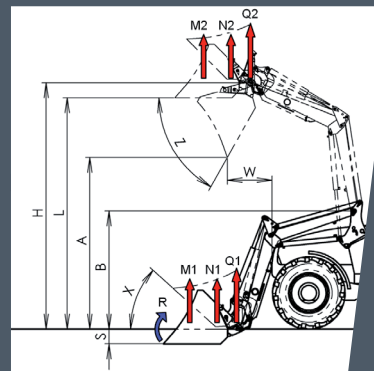

- Connected to the tractor screen
- Control linked to the tractor joystick
- All 12 functions fully accessible over one connection on the tractor interface
- New level of comfort and higher safety standards
- Electronic hydraulic parallel guidance function (only for FS front loaders)



# ProfiLine ISOBUSConnected

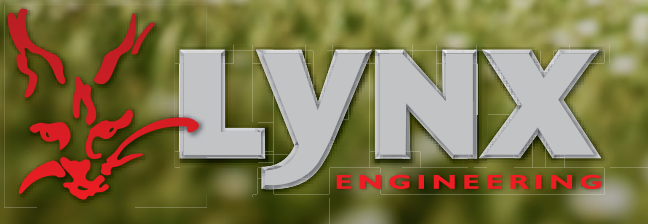

Lynx Engineering, Wharf Works,  
Long Buckby,  
Northamptonshire, NN6 7PP  
Tel: 01327 843215  
Email: [info@lynx-engineering.co.uk](mailto:info@lynx-engineering.co.uk)



**MORE WAYS TO ADD MORE PRODUCTIVITY**  
[www.lynx-engineering.co.uk](http://www.lynx-engineering.co.uk)