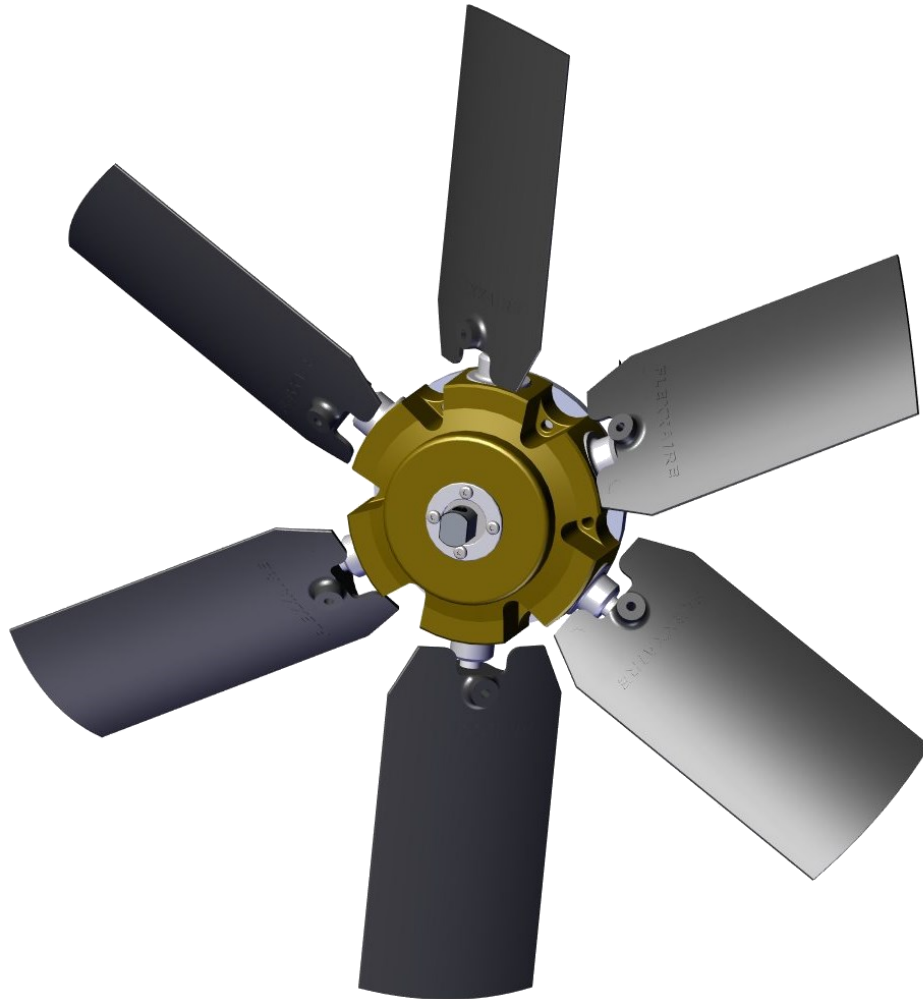




# FLEXXAIRE

**INSTALLATION AND SERVICE MANUAL  
FOR THE  
SERIES 500 FAN  
(HYDRAULIC CONTROL)**



PUBLICATION No. 01910

Revision 0

Printed in Canada



## 1.1 INTRODUCTION

Thank you for purchasing a Flexxaire Fan System.

Flexxaire takes great pride in designing, manufacturing and assembling its products for many years of use.

This manual (P/N **01910**) is produced to assist in the installation, operation and maintenance of the Flexxaire® Series 500 Fan Systems using Hydraulic actuation.

Flexxaire has made every effort to ensure that the information contained in this manual is correct and complete at the time of printing. Flexxaire will assume no responsibility for any errors or omissions. If you have any questions regarding this manual, any other document provided with your fan system or any questions not answered by this manual, please contact:

**Flexxaire Inc.**

**Product Support Department**

**10430-180 Street**

**Edmonton, Alberta, Canada**

**T5S-1C3**

**Phone: 780-483-3267**

**Fax: 780-483-6099**

**Monday to Friday 7:00 am to 3:30 pm MST**

## 1.2 IMPORTANT SAFETY INFORMATION

The safety information in this publication is to be used in conjunction with the safety information supplied from the original machine manufacturer. Please refer to all safety information supplied, prior to doing any work on the fan assembly or any other component to assure safety.

**Improper operation, maintenance or repair of this product can be dangerous and could result in injury or death.**

Always use Genuine Flexxaire parts and components or Flexxaire approved parts and components. The use of unapproved parts and/or components will void the factory warranty.

**Do not operate or perform any maintenance on this product until you have read and understand the operation and maintenance information. Please contact Flexxaire or an approved dealer for any information that you may require.**

**The person(s) servicing the product may be unfamiliar with many of the systems or components on the product. It is important to use caution when performing any type of service work. Knowledge of the product and/or its components is important before the removal or disassembly of any component.**

## 1.2.1 PROTECTIVE EQUIPMENT

Always wear protective glasses, protective shoes and any other protective equipment as required by law and/or your company safety program.

## 1.2.2 PRESSURIZED FAN HUB

The hub assembly is spring loaded. If disassembly of the hub is required, take caution that you are well protected from the hub's release which may be sudden and pose an impact related injury.

Also make sure that the internal pressure is released. Consult the hydraulic control instructions in this manual.

## 1.2.3 HOT FLUIDS AND PARTS

To avoid burns, be alert for hot parts on the assembly or the machine that have just been stopped and have hot fluid in lines, tubes and compartments.

## 1.3 FAN SPECIFICATIONS

The following needs to be considered prior to the installation of the Flexxaire Fan System. If your situation is listed in this section, **DO NOT INSTALL THE FAN.** Damage and/or injury may occur.

### 1.3.1 MOUNTING

**WARNING:** This fan is not designed to be mounted onto a crank shaft or crank shaft pulley. Torsional vibration from crankshafts will damage the fan and could result in machine damage and serious injury.

### 1.3.2 FAN BLADE TIP SPEED

**WARNING:** The fan system must not exceed a blade tip speed of 20,000 feet/minute. Exceeding this speed may cause damage to and/or failure of the fan, which in turn may cause injury or death, or damage to the radiator and surrounding equipment.

To calculate the blade tip speed, use the following formula:

$$\text{Fan Diameter (Inches)} \times 3.14 \times \text{Fan RPM}$$

**12**

If your calculated tip speed exceeds 20,000 ft/min, contact Flexxaire directly, prior to installation. **It is important to use Fan RPM and NOT engine RPM.**

## 1.4 FAN OVERVIEW

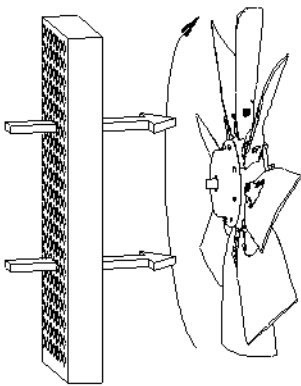
Flexxaire's Series 500 fan systems are designed to minimize overheating caused by debris plugged radiators, screens and guards, and reduce overcooling in low ambient temperatures. The blades of the Series 500 vary pitch, not speed, to control air flow volume and direction.

### How your Series 500 works:

The Series 500 can be purchased as a hydraulically actuated variable pitch fan. The blades are held in full pitch by a heavy spring. Hydraulic pressure is applied to the control line, the pitch of the blade is reduced and then reversed. When the pressure is released, the fan blades return to their default position.

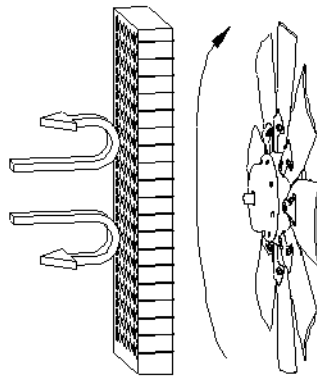
The Series 500 fan has a number of important features:

1. **Fail Safe Operation:** The blades are spring loaded into the default full pitch position. If the fan loses pressure, the fan will default to full pitch and act like a fixed pitch fan giving maximum cooling.
2. Depending on the control kit ordered (see Section 2.0), the fan can be run in a neutral pitch (or any pitch in between) to solve overcooling problems and save horsepower and fuel.
3. When purging, there are no horsepower spikes, in fact, the horsepower drops off as you pass through neutral pitch, then slowly builds as pitch increases.



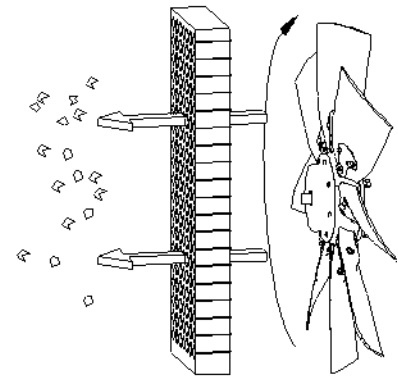
NORMAL OPERATION

EFFICIENT COOLING



NEUTRAL PITCH

STOP AIR FLOW  
PREVENT OVERCOOLING  
SAVE HORSEPOWER



PURGE

CLEAN RADIATOR  
PREVENT OVERHEATING

## 2.0 CONTROL KITS

Due to the variability of machines that the Series 500 fan may be installed on, the fan does not include any control components. Flexxaire has a number of different control kits available to suit a wide range of applications:

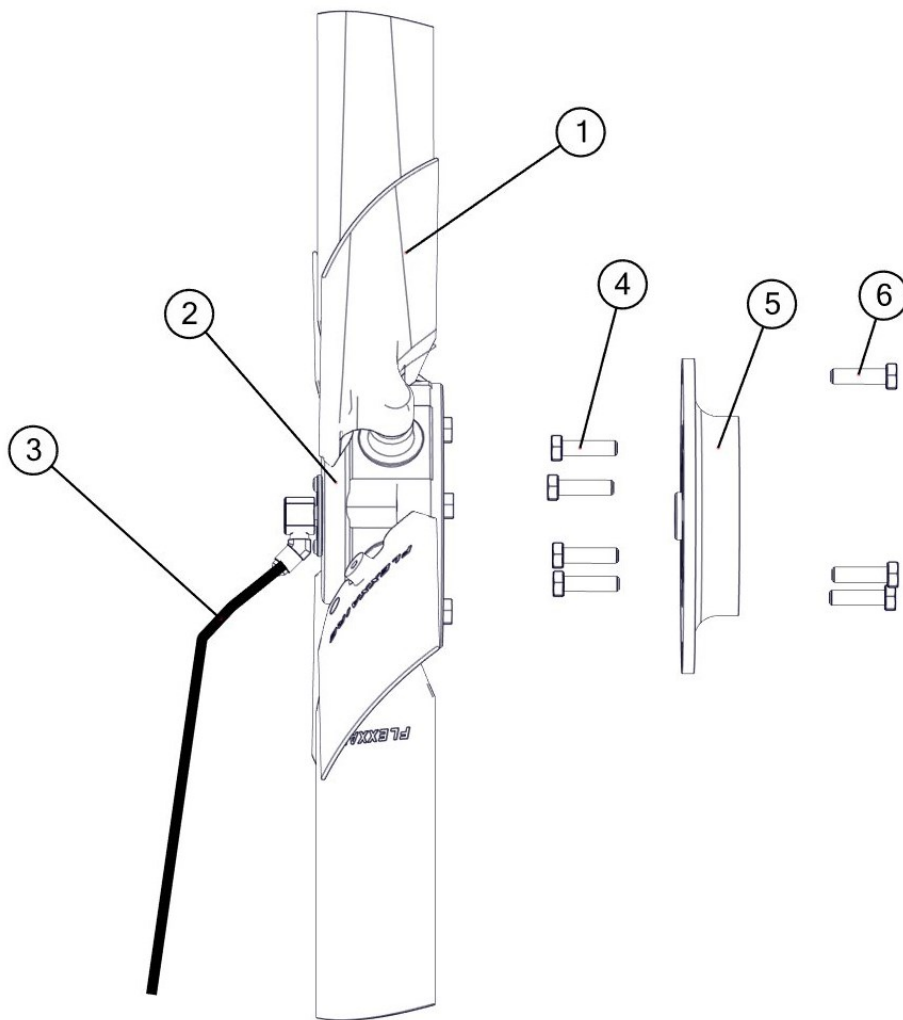
### HYDRAULIC CONTROL:

- 2 Position kit (Manual Purge)
- 2 Position kit with timer (Manual and Auto Purge)
- Infinitely Variable Pitch Controller (IVP fan control)
- Available in 12V and 24V configurations

**Contact Flexxaire or your dealer for details and availability.**

## 2.1 MAJOR COMPONENTS

The Series 500 Fan Assembly can be identified by several external components as shown in **Figure 1**. Use this diagram for terminology and major component identification.



**Figure 1**

### MAJOR COMPONENTS:

- |                   |                           |                       |
|-------------------|---------------------------|-----------------------|
| 1. Blade Assembly | 3. Pressure Line          | 5. Adapter Plate      |
| 2. Hub Assembly   | 4. Mounting Adapter Bolts | 6. Hub Mounting Bolts |

## 2.2 EXISTING FAN REMOVAL

The following is a general description for the removal of an existing fan and the installation of a Flexxaire Series 500 Fan.

1. Remove fan guards and safety equipment to gain access to the existing fan.
2. Loosen belt(s) and remove existing fan hardware as required.
3. Clean mounting surface of the fan drive.

## 2.3 INSTALLATION

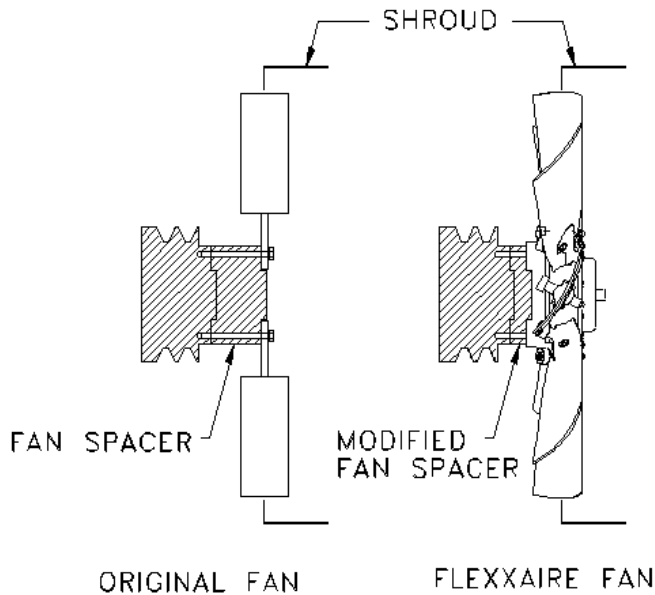
### 2.3.1 Mounting Adapters

The Series 500 fan is supplied with a pre-machined mounting adapter plate. Pre-machined mounting adapters are machined for your pilot and bolt circle.

For some applications, a wider 2-piece adapter may be used, and the necessary hardware for assembling the 2 parts together will be included. This 2-piece adapter may be pre-assembled.

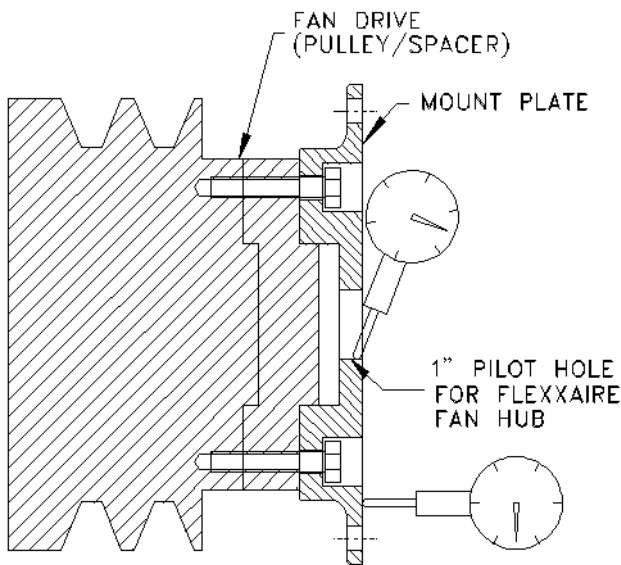
### 2.3.2 Fan Position

Ideally the fan should be centered in the shroud (30-70% immersion is acceptable). This may require modification or removal of the fan spacer or modification of the shroud. See **Figure 2**.



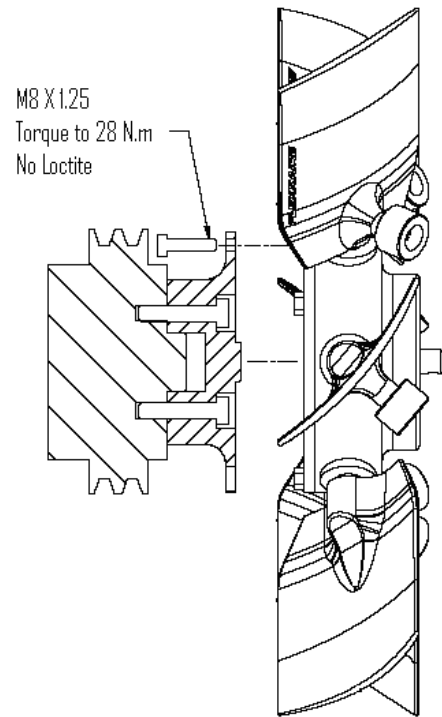
**Figure 2**

1. Install the Flexxaire supplied mounting adapter using bolts from the original fan. If the bolt length needs to be changed, use an equivalent or better grade of bolt. Follow original equipment manufacturer's torque and thread locking specifications when installing the mounting adapter to the fan drive. Refer to **Figure 3**.

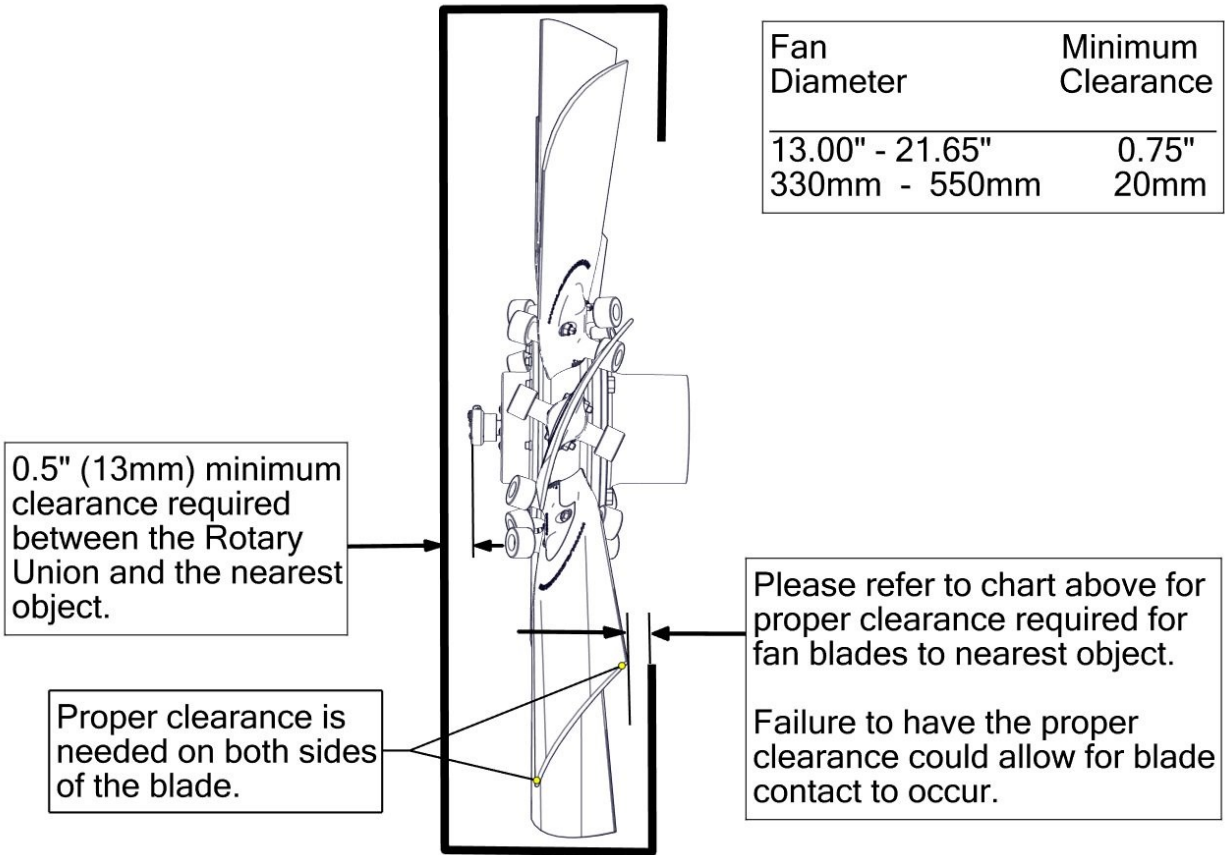


**Figure 3**

2. Set up dial gauge to measure axial deviation of the mounting adapter on the fan mounting surface. Deviation should not exceed 0.005". Refer to **Figure 3**.
3. Set up dial gauge to measure radial deviation of the mounting adapter on the 1" pilot hole surface. Deviation should not exceed 0.005". Refer to **Figure 3**.
4. Remove the shipping plug from the rear of the fan. Place the Series 500 fan onto the mounting adapter and torque the M8 bolts to 21 ft-lbs (47 N.m). Do not use loctite. Refer to **Figure 4**.



**Figure 4**



**Figure 5**

**WARNING:** Failure to have correct blade clearance could result in blade contact that can cause extensive damage to people and equipment.

**WARNING:** Failure to have the correct clearance for the rotary union could result in premature failure of the rotary union and/or damage to objects contacting the rotary union.

**3.0 HYDRAULIC SPECIFICATIONS**

Flexxaire supplies a number of hydraulic control options, but the Series 500 Hydraulic versions can be operated using any hydraulic source that meets the general specifications listed below. If your machine has hydraulics on board then this source should be available.

**Series 500 Hydraulic General Specifications:**

- Full Pitch** (default position): **0 psi (0 bar)**
- Neutral Pitch** (Stop air position): **~140 psi (9.7 bar)**
- Reverse Pitch** (Purge position): **220 psi (15.2 bar)**
- Maximum allowable pressure:** **500 psi (34.5 bar)**

**3.1 HYDRAULIC LINE SPECIFICATIONS**

**Series 500**

1. The connection on the rotary union is a 1/8NPT female thread. Flexxaire installs a 1/8" NPT to #4 JIC adapter to the rotary union.
2. The fitting on the ends of the default hose is a #4 JIC. An adapter is used to mate the hose to the #6ORB port on the manifold.
3. If supplying your own hose, it is recommended to use a hose that is as small as possible. The potential exists that a large, heavy hose with bulky fittings could create a side load on the rotary union, just due to the weight of the hose. Side loads can drastically reduce the life of the rotary union.
4. Maximum allowable working hydraulic pressure is 500 psi (34.5 bar).

### 3.2 HYDRAULIC LINE ROUTING

Care needs to be taken when determining how to route the hydraulic line for Hydraulic versions of the fan. Incorrect routing could lead to damage of the fan blades and premature wear and/or failure of the rotary union.

The fan is shipped with a default hose assembly attached to the hub assembly. Contact Flexaire if a different hose length of different fittings are required for future orders.

The hose is attached at the Flexaire factory to avoid unnecessary side loads to the bearings of the rotary union that can be applied every time the hose is attached or detached from the rotary union.

Using Figures 6 to 10 inclusive, route the hydraulic hose in such a way that eliminates the side loading of the Rotary Union. Any slack left in the hydraulic line must also be clear of any of the moving components of the fan.

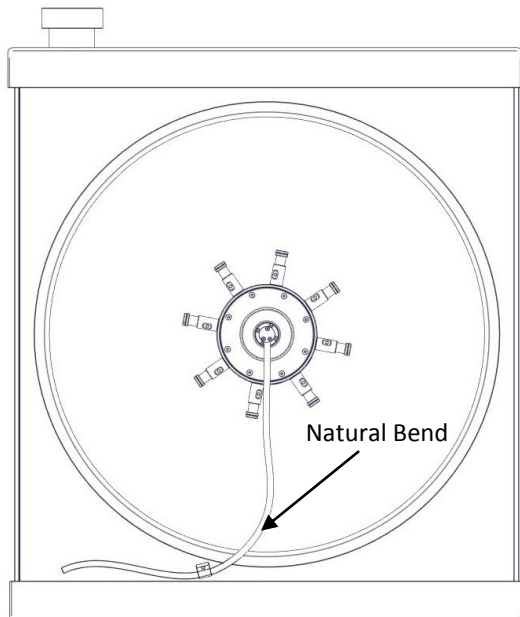
Figures 6, 7 and 8 show acceptable routings of the hydraulic line that should eliminate the side loading of the rotary union of the fan.

Figure 9 and 10 are examples of a routing that needs to be avoided since it will create side loading of the rotary union and cause it to fail prematurely or be pulled out of the fan assembly.

**WARNING:** Do not secure the hydraulic line so tight as to cause a side load on the rotary union. Failure of the bearings could result.

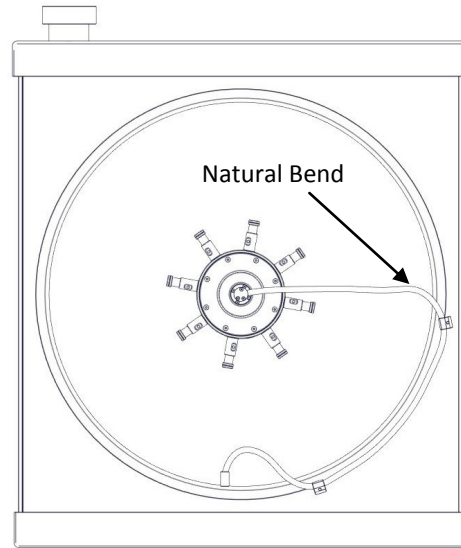
**WARNING:** Do not secure the hydraulic hose so loose that the hose could contact the blades due to sudden air reversal, vibration, etc....

**WARNING:** Ensure that you have the minimum clearance between the rotary union and closest obstruction as per Figure 5 on page 5.



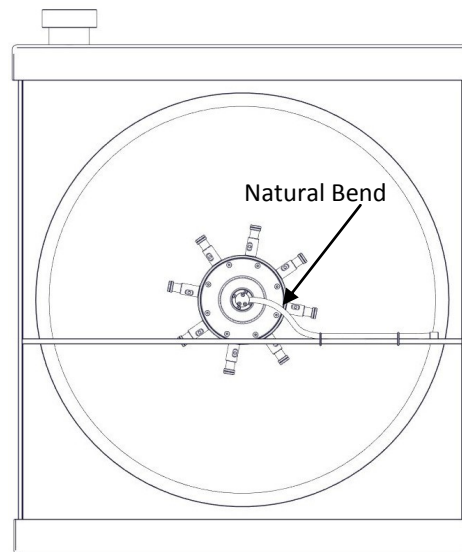
**Figure 6**

In figure 6, the routing is the hydraulic line on the outside of the shroud. A natural bend is created by installing a hose clamp as close to 90 degrees to the running of the Hydraulic Line to the fan.



**Figure 7**

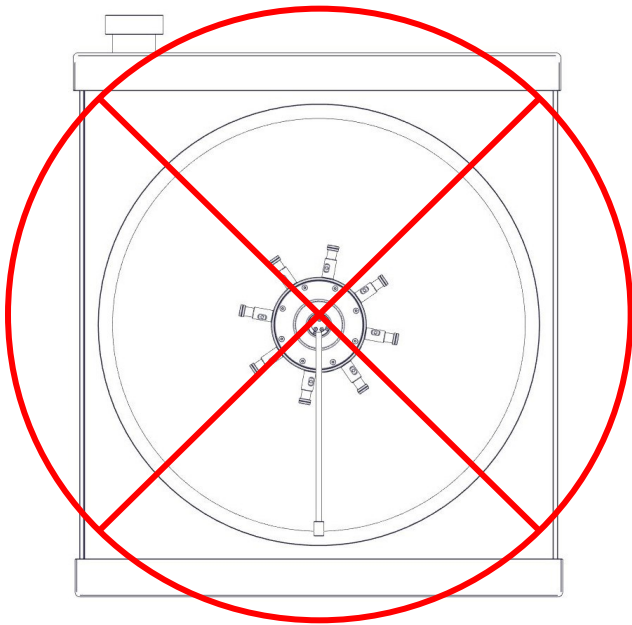
In figure 7, the routing of the hydraulic line runs through the shroud. A natural bend is created by installing a hose clamp as close to 90 degrees to the running of the Hydraulic Line to the fan. A second (or additional) clamps can be used as required to assist in the final install of the hydraulic line.



**Figure 8**

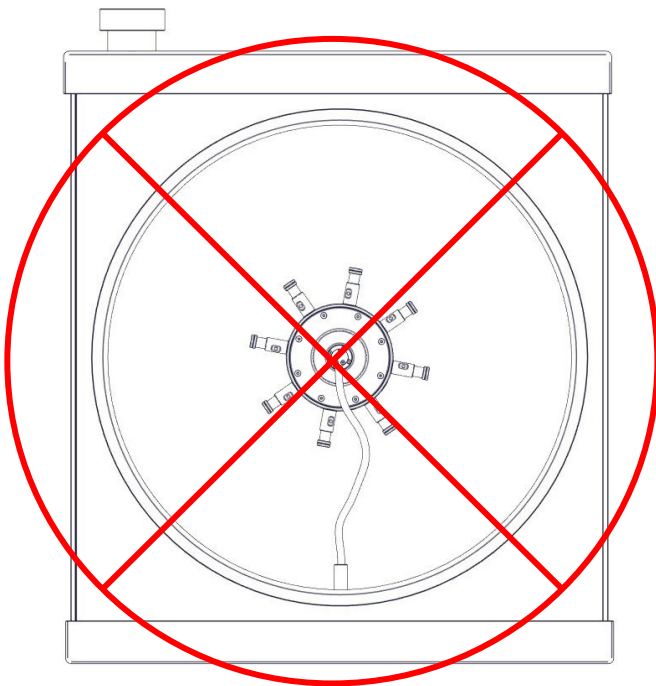
In figure 8, the routing of the hydraulic line runs along a cross member. A natural bend is created by creating a small bend in the hose and a clamp on the cross member. The hose needs to be secured to the member with an appropriate clamp that holds the line in place and does not fail due to heat.





**Figure 9**

In figure 9, the hydraulic line routing will create a side load on the rotary union that will lead to premature failure of the rotary union or it could be pulled out of the fan assembly. This routing needs to be avoided.



**Figure 10**

In figure 10, the hydraulic line routing will create a whipping effect that causes a side load on the rotary union that will lead to premature failure of the rotary union or it could be pulled out of the fan assembly. The extra slack could make contact with the blades. This routing needs to be avoided.

#### 4.0 INSTALL CHECKLIST

CHECK	YES	NO
Does fan rotate in default and full reverse pitches without obstruction?	<input type="checkbox"/>	<input type="checkbox"/>
Has the side load on the pressure line been minimized?	<input type="checkbox"/>	<input type="checkbox"/>
Has the pressure line been constrained to prevent contact with the blades?	<input type="checkbox"/>	<input type="checkbox"/>
Is the pressure line flexible enough to accommodate relative movement between the radiator and engine?	<input type="checkbox"/>	<input type="checkbox"/>
Are any of the blades damaged?	<input type="checkbox"/>	<input type="checkbox"/>
Does the rotary union rotate freely?	<input type="checkbox"/>	<input type="checkbox"/>
Are there any pressure leaks in the system?	<input type="checkbox"/>	<input type="checkbox"/>
Are all screens and guards secured?	<input type="checkbox"/>	<input type="checkbox"/>
Have you recorded the fan S/N for future reference? <b>S/N</b> _____	<input type="checkbox"/>	<input type="checkbox"/>

#### 5.0 SERVICE AND MAINTENANCE

Flexaire's Series 500 fan hub is fully sealed with o-rings, and contains a small amount of grease. As a result, the fan should not require any maintenance.

#### 5.1 VISUAL INSPECTIONS

Under normal operating conditions, Series 500 fans do not require any scheduled maintenance and are built to provide thousands of hours of trouble free service. In moderate to extreme operating conditions a visual inspection of the moving parts is recommended from time to time to safeguard against fan blade damage which could lead to equipment downtime and/or other damages.

#### 5.2 MECHANICAL REVIEW

1. Ensure that the fan fully reverses pitch.
2. Check for leaks in the rotary union.
3. Check that the rotary union bearings rotate smoothly.
4. Verify that you have the correct blade clearance as per **Figure 5** on page 5.

**Note:**

The blades will show streaking marks from oil at initial start up of the fan. This is due to oil from the assembly process used during manufacturing. It will disappear after 10 hours of operation of the fan.

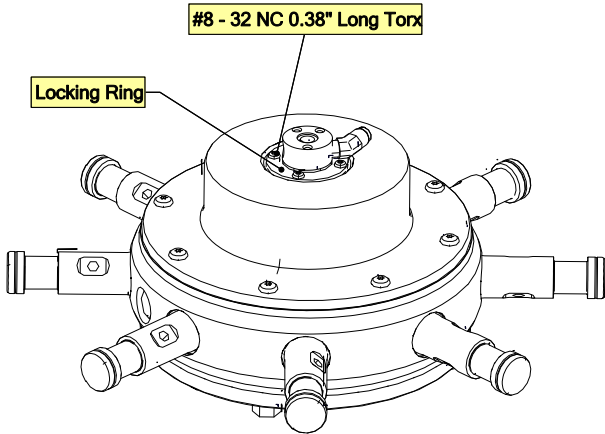
**6.0 ROTARY UNION**

The rotary union used in the fan hub is lubricated for life and requires no additional maintenance other than periodic inspection to determine if normal wear has caused the union to leak.

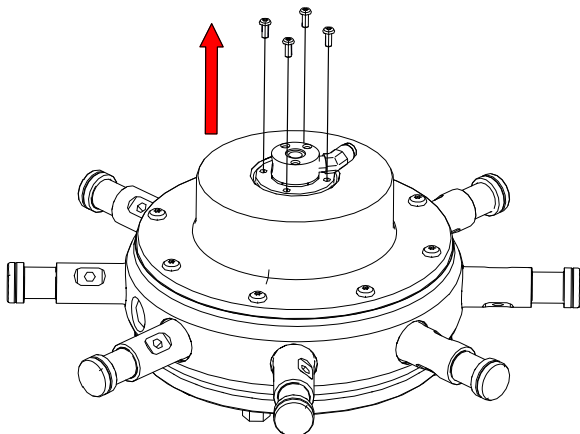
The retaining system used to lock the rotary union into the fan system is the Locking Ring design.

In addition, some fans are supplied with a Pitch Sensor or are Pitch Sensor Ready. These fans have a pin installed internally in the piston that travels through rotary union when installed. A jig is supplied with rotary union to verify pin center for applicable models. If your design does have the internal pin, please refer to Section 6.2 for proper use of jig.

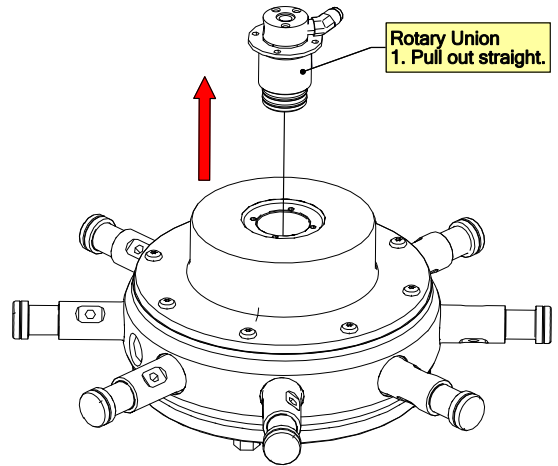
**6.1 ROTARY UNION REPLACEMENT LOCKING RING**



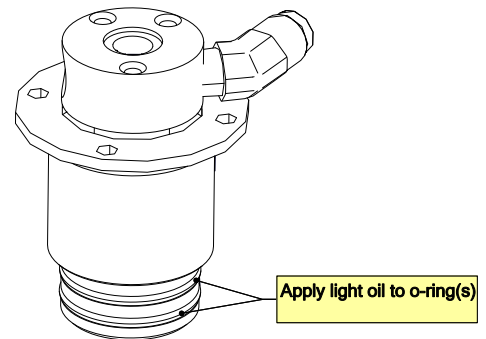
**Figure 11**



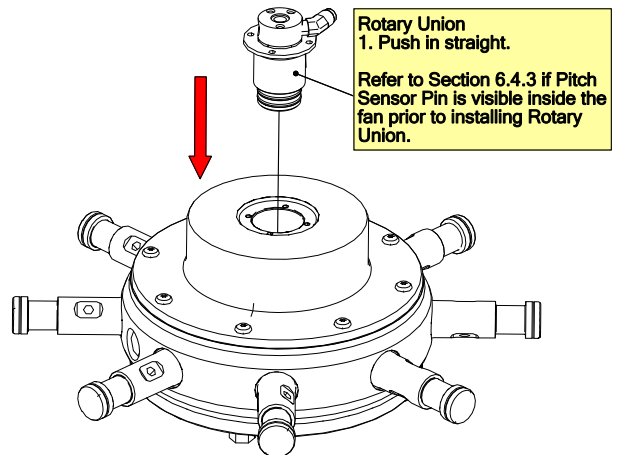
**Figure 12**



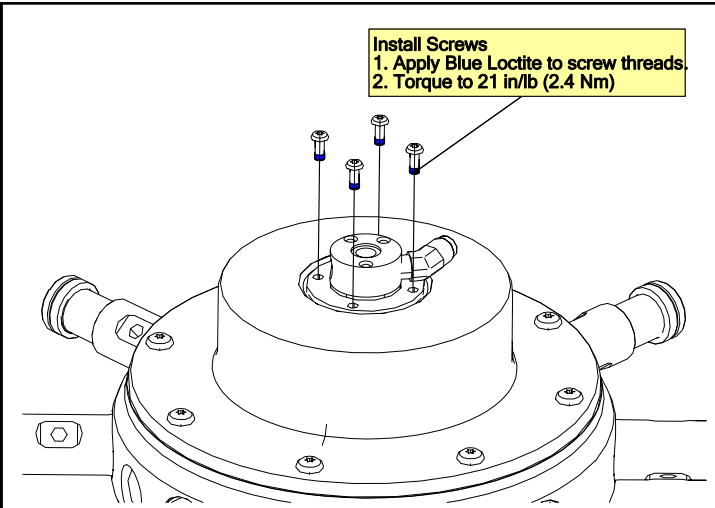
**Figure 13**



**Figure 14**

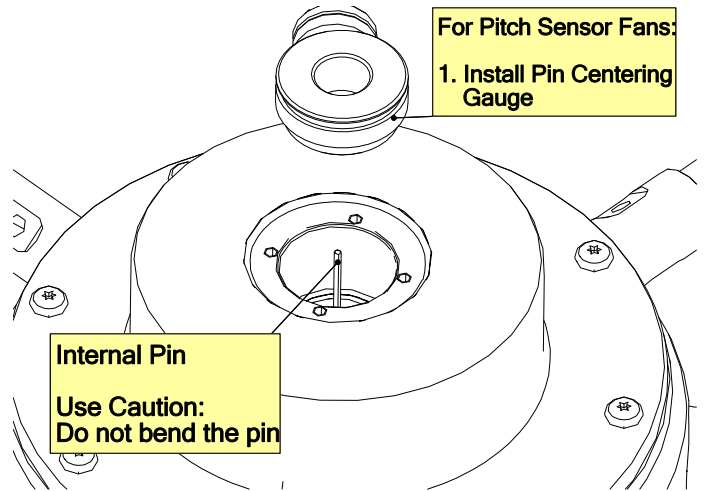


**Figure 15**

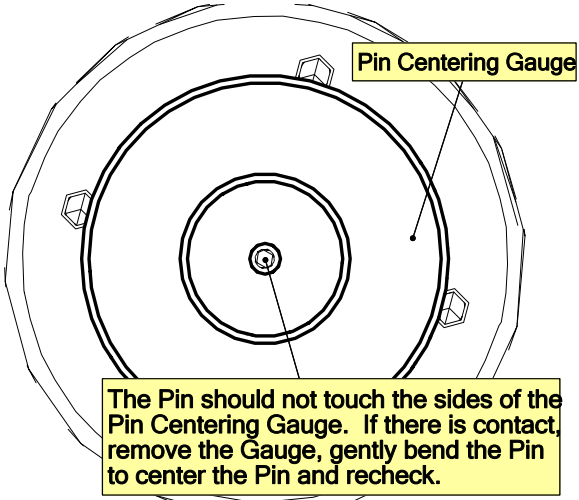


**Figure 16**

**6.2 INTERNAL PIN VERIFICATION FOR PITCH SENSOR ENABLED/PITCH SENSOR READY FANS**



**Figure 17**



**Figure 18**

The Pin must be adequately centered so that it does not contact the inside of the pitch sensor or damage to the sensor will occur. Flexxaire has provided a Pin Centering Gauge to test for accurate centering. Place the Pin Centering Gauge over the Pin. The Pin should not touch the sides of the Pin Centering Gauge. If there is contact, then remove the Gauge, gently bend the pin to center the pin, and recheck.